

Rexroth MKE synchronous motors for potentially hazardous areas acc. to ATEX and UL/CSA guidelines

R911297663
Edition 03

Project Planning Manual



Title	Rexroth MKE synchronous motors for potentially hazardous areas acc. to ATEX and UL/CSA guidelines
Type of Documentation	Project Planning Manual
Document Typecode	DOK-MOTOR*-MKE*GEN2***-PR03-EN-P
Internal File Reference	Document Number: 120-1500-B326-03/EN
Purpose of Documentation	This documentation describes ... <ul style="list-style-type: none"> • Explains the features of the product, possibilities for use, conditions for use and operational limits • Contains technical data regarding the motors that can be supplied • Provides information regarding product selection, handling and operation

Record of Revisions

Description	Release Date	Notes
DOK-MOTOR*-MKE*GEN2***-PR01-EN-P	06/03	1 st edition (not printed)
DOK-MOTOR*-MKE*GEN2***-PR03-EN-P	02/04	2 nd edition
DOK-MOTOR*-MKE*GEN2***-PR03-EN-P	03/04	3 rd edition

Copyright © 2004 Bosch Rexroth AG

Copying this document, giving it to others and the use or communication of the contents thereof without express authority, are forbidden. Offenders are liable for the payment of damages. All rights are reserved in the event of the grant of a patent or the registration of a utility model or design (DIN 34-1).

Validity The specified data is for product description purposes only and may not be deemed to be guaranteed unless expressly confirmed in the contract. All rights are reserved with respect to the content of this documentation and the availability of the product.

Published by Bosch Rexroth AG
Bgm.-Dr.-Nebel-Str. 2 • D-97816 Lohr a. Main
Telephone +49 (0)93 52/40-0 • Tx 68 94 21 • Fax +49 (0)93 52/40-48 85
<http://www.boschrexroth.com/>
Dept. BRC/EDM2 (MH/JW)

Note This document has been printed on chlorine-free bleached paper.

Contents

1	Introduction to the Product	1-1
1.1	MKE.....	1-1
1.2	About this documentation.....	1-3
2	Important Instructions on Use	2-1
2.1	Intended Use.....	2-1
	Introduction.....	2-1
	Fields of Use and Application.....	2-2
2.2	Non-Intended Use.....	2-2
3	Safety Instructions for Electric Drives and Controls	3-1
3.1	Introduction.....	3-1
3.2	Explanations.....	3-1
3.3	Hazards by Improper Use.....	3-2
3.4	General Information.....	3-3
3.5	Protection Against Contact with Electrical Parts.....	3-5
3.6	Protection Against Electric Shock by Protective Low Voltage (PELV).....	3-6
3.7	Protection Against Dangerous Movements.....	3-7
3.8	Protection Against Magnetic and Electromagnetic Fields During Operation and Mounting.....	3-9
3.9	Protection Against Contact with Hot Parts.....	3-10
3.10	Protection During Handling and Mounting.....	3-11
3.11	Battery Safety.....	3-12
3.12	Protection Against Pressurized Systems.....	3-13
4	Technical data	4-1
4.1	Description.....	4-1
	Operating Modes.....	4-2
	Definition of Parameters.....	4-3
4.2	Technical Data MKE037.....	4-6
	Technical data sheet and characteristic curves.....	4-6
	Shaft loads.....	4-8
4.3	Technical Data MKE047.....	4-10
	Technical data sheet and characteristic curves.....	4-10
	Shaft loads.....	4-12
4.4	Technical Data MKE098.....	4-14
	Data sheet and characteristic curves.....	4-14
	Shaft loads.....	4-16
4.5	Technical Data MKE118.....	4-18

Data sheet and characteristic curves	4-18
Shaft loads	4-22
5 Dimensional Details	5-1
5.1 Size 037	5-1
5.2 Size 047	5-4
5.3 Size 098	5-7
5.4 Size 118	5-10
6 Type Code	6-1
6.1 Description	6-1
6.2 Type code size 037	6-6
6.3 Type code size 047	6-7
6.4 Type code size 098	6-8
6.5 Type code size 118	6-9
7 Accessories and Options	7-1
7.1 Motor encoder	7-1
7.2 Holding Brakes	7-3
7.3 Gearboxes	7-4
Planetary gearbox	7-4
8 Connection System	8-1
8.1 Overview	8-1
Connection temperature control	8-2
Additional protective conductor	8-2
Connection Cable	8-3
8.2 Motor connection according to European standard (EN)	8-4
8.3 Connection according to American standard (UL)	8-5
8.4 Dimensioning power cable	8-6
8.5 Recommendation for handling and application, Cable assembly in drag chains	8-7
9 Notes Regarding Application	9-1
9.1 Hazardous areas	9-1
Designation and definition	9-1
Application conditions for MKE motors	9-6
Type test of the motors according to European standard (EN)	9-9
Type test of the motors according to American standard (UL)	9-11
9.2 Setup Height and Ambient Temperature	9-13
9.3 Protection class	9-14
9.4 Compatibility	9-14
9.5 Design and Installation Positions	9-15
9.6 Prime Coat and Housing Varnish	9-15
9.7 Vibration and Shock Loads	9-16
9.8 Output shaft and shaft sealing ring	9-17
Smooth shaft	9-17

Output shaft with fitting key.....	9-17
Output Shaft With Shaft Sealing Ring	9-18
9.9 Bearings and Shaft Load	9-20
9.10 Holding Brakes.....	9-24
Selecting Holding Brakes.....	9-25
Sizing of Holding Brakes (Application)	9-26
9.11 Acceptance and allowance	9-27
Motors in EU style	9-27
Motors in UL style.....	9-28
10 Handling, Transport and Storage	10-1
10.1 Supplied Condition	10-1
Factory-attached test.....	10-1
Test on the customer side	10-1
10.2 Identification.....	10-2
Shipping documents and delivery note.....	10-2
Name plate.....	10-2
10.3 Transport and storage	10-3
11 Installation	11-1
11.1 Safety	11-1
11.2 Skilled technical personnel	11-1
11.3 Mechanical mounting – Motor assembly	11-2
Mounting the flange	11-2
Preparation	11-2
Assembly	11-3
11.4 Electrical connection – Motor connection	11-3
Motor connection according to European standard (EN)	11-4
Motor connection according to American standard (UL)	11-11
12 Startup, Operation and Maintenance	12-1
12.1 Commissioning.....	12-1
12.2 Operation	12-1
12.3 Deactivation	12-2
12.4 Maintenance	12-2
Cleaning.....	12-2
Bearing	12-3
Connection Cable	12-3
Holding brake	12-4
Changing the battery	12-5
12.5 Troubleshooting	12-7
12.6 Dismantling	12-7
12.7 Waste disposal.....	12-8
13 Appendix	13-1
13.1 List of standards.....	13-1

13.2 Selection of connection cable	13-3
Power cables.....	13-4
Encoder cable	13-7
13.3 Declaration of conformity.....	13-9
14 Service & Support	14-1
14.1 Helpdesk.....	14-1
14.2 Service-Hotline.....	14-1
14.3 Internet.....	14-1
14.4 Vor der Kontaktaufnahme... - Before contacting us... ..	14-1
14.5 Kundenbetreuungsstellen - Sales & Service Facilities.....	14-2
15 Index	15-1

1 Introduction to the Product

1.1 MKE

The MKE-servo motors of the second generation fulfill the specifications according to ATEX and UL/CSA in one class. This permits the worldwide use of Rexroth MKE-motors with one machine design only.

In connection with the drive devices of Rexroth, the MKE-servomotors generates drive systems with high functionality for the use in hazardous areas.

Performance list MKE-motors are available in the following power spectrum:

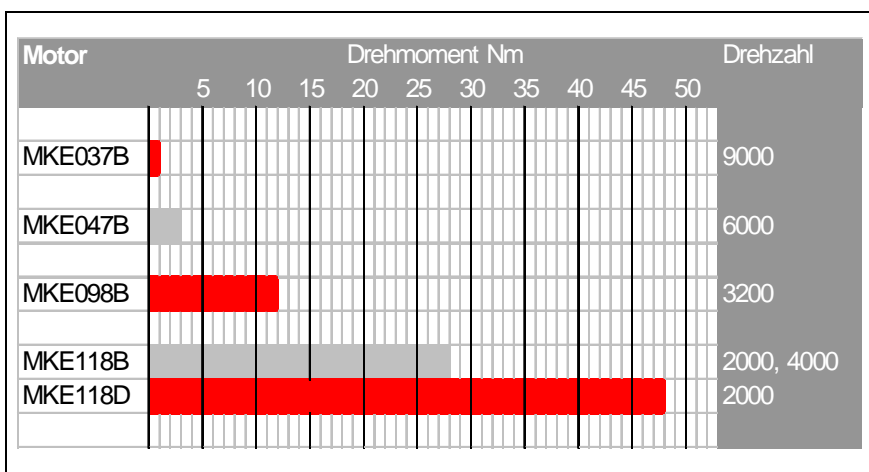
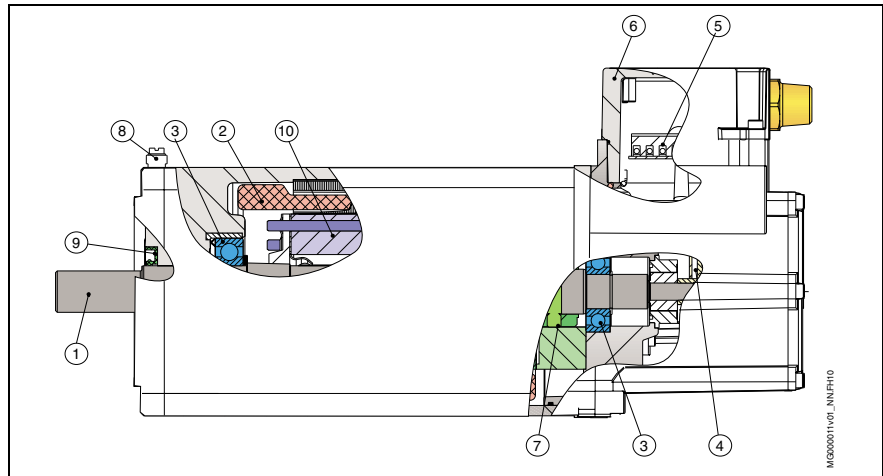

Fig. 1-1: MKE power graduation

Performance feature MKE motors are characterized by the following advantages:

- The motor construction in "Flameproof Enclosures "d" " according to EN 50 014 : 1992
- High operational reliability
- Maintenance-free operation (owing to the brushless design and use of bearings grease-lubricated for their entire service life)
- Use under adverse environmental conditions is possible (owing to the completely closed motor design in IP 65 degree of protection)
- Overload protection (by means of motor-temperature control)
- High performance data
- High dynamics (owing to the favorable ratio of torque to inertia mass)
- High overload capability (owing to the favorable heat dissipation from the stator windings to the outside wall of the motor housing)
- Peak torque utilizable across a wide speed range (owing to electronic commutation)
- Continuous start-stop operation possible with high repeat frequencies (owing to electrical commutation)
- Easy attachment to the machine (owing to flange according to DIN 42948) 11.65)
- Any installation position desired
- Simple and fast commissioning (by data memory)

Design and components MKE motors are permanent-magnet motors with electronic commutation. Special magnet materials permit the motors to be designed with low inertia masses. The following figure shows the principal design of MKD motors.



- (1): Shaft
- (2): Stator with winding
- (3): Bearing
- (4): Motor encoder
- (5): Connection unit
- (6): Terminal box lid
- (7): Holding brake (optional)
- (8): Grounding clamp
- (9): Shaft sealing ring
- (10): Rotor with permanent magnets

Fig. 1-2: Design of MKE motors

Constructions

MHE motors are available in various designs. Conditional upon existing national instructions and standards, the MKE motors have to be differentiated from the housing according to:

- E according to European Standard (EU) and
- U according to American Standard (UL)

unterteilt werden.

The connection technology of the MKE motors is variously processed according to the national instructions.

Note: Please heed the notes according to the guilty national instructions in the chapter "Application Notes".

1.2 About this documentation

Structure of this Document Edition

The present documentation contains safety regulations, technical data, and operating instructions for MKE motors. The individual chapters can be subdivided into the following focal points:

Chapter	Title	Content
1	Introduction to the Product	General information
2	Important Instructions on Use	Safety
3	Safety notes	
4	Technical data	Product description (for planners and machine constructors)
5	Dimensional Details	
6	Type Code	
7	Accessories and Options	
8	Connection System	
9	Operating condition and application instructions	Practical (for operating and maintenance personnel)
10	Handling, Transport and Storage	
11	Installation	
12	Startup, Operation and Maintenance	General information
13	Appendix	
14	Service and Support	
15	Index	

Fig. 1-3: Document Structure

Modifications as Compared with the Predecessor Version

The following list shows the modifications as compared with the predecessor version DOK-MOTOR*-MKE*GEN2***-PR02 -EN-P

Where?	What?
Chapter 3.9	Safety note "Protection against contact with hot parts" appendix.
Chapter 4.4	New: Technical data and characteristic curve MKE098B-058
Chapter 4.5	New: Technical data and characteristic curve MKE118D-035
Chapter 6.4	New: Type code size 098
Chapter 9.1	Revision of section "Application conditions for motors MKE".
Chapter 11.4	Fig. 1-4: Grommets for Ex-threads (adjustment of grommet size for encoders)
Chapter 12.4	Maintenance – battery change

Fig. 1-5: Modifications

Note: This list does not lay claim to completeness. The author reserves the right to neglect minor modifications in this list.

Additional documentation

Note: If the present documentation contains references to advanced documentations, the version of the latter is always represented in bold and underlined type (e.g. **06**). If documentations are ordered, their version may be a higher one!

Standards

This documentation refers to German, European and international technical standards. Documents and sheets on standards are subject to copyright protection and may not be passed on to third parties by Rexroth. If necessary, please address the authorized sales outlets or, in Germany, directly to:

BEUTH Verlag GmbH

Burggrafenstrasse 6

10787 Berlin

Phone +49-(0)30-26 01-22 60, Fax +49-(0)30-26 01-12 60

Internet: <http://www.din.de/beuth>

E-mail: postmaster@beuth.de

Outside Systems

Documentation for external systems which are connected to Rexroth components are not included in the scope of delivery and must be ordered directly from the particular manufacturers.

Feedback

Your experiences are an essential part of the process of improving both product and documentation.

Please do not hesitate to inform us of any mistakes you detect in this documentation or of any modifications you might desire. We would appreciate your feedback.

Please send your remarks to:

Bosch Rexroth AG
Dep. BRC/EDM2
Bürgermeister-Dr.-Nebel-Strasse 2
D-97816 Lohr, Germany
Fax +49 (0) 93 52 / 40-43 80

2 Important Instructions on Use

2.1 Intended Use

Introduction

In their design and manufacture, the products by Bosch Rexroth reflect the latest state of technology. Before they are delivered, they are checked for their operationally safe state.

The products may only be used as intended. If they are not used as intended, situations may arise resulting in injuries to property and persons.

Note: For damage caused by products not being used as intended, Bosch Rexroth, as manufacturers, do not give any warranty, assume any liability, or pay any damages. Any risks resulting from the products not being used as intended, are the sole responsibility of the user.

Before using Bosch Rexroth products, the following requirements must be fulfilled so as to ensure that they are used as intended:

- Anybody handling one of our products in any manner must read and understand the appropriate safety instructions and the intended use.
- If they are hardware components, the products concerned must be left in their original state, i.e. it is not permitted to modify them structurally. Software products may not be decompiled; their source codes may not be altered.
- Damaged or defective products may not be installed or put into operation.
- It must be ensured that the products are installed, operated and serviced according to the regulations and environmental conditions specified in the documentation.

Fields of Use and Application

AC servo motors of the MKE series by Bosch Rexroth are intended to be used as servo and main drive motors. The following are typical fields of application:

- Machine tools
- Printing and paper-processing machines
- varnish plants,
- Automation and handling

Unit types with different driving powers and different interfaces are available for an application-specific use of the motors.

Controlling and monitoring of the motors may require connection of additional sensors and actuators.

Note: The motors may only be used with the accessories specified in the documentation. Components which are not expressly named may neither be mounted nor connected. The same applies to cables and lines.

The motors may be operated only in the expressly specified component configurations and combinations and with the software and firmware specified in the appropriate functional description.

Any connected drive controller must be programmed before startup, in order to ensure that the motor executes the functions specific to the particular application.

The motors may only be operated under the assembly, mounting and installation conditions, in the position of use, and under the environmental conditions (temperature, degree of protection, humidity, EMC, and the like) specified in this documentation.

2.2 Non-Intended Use

Any use of the motors outside of the fields of application mentioned above or under operating conditions and technical data other than those specified in this documentation are considered to be “non-intended use”.

MKE motors may not be used if . . .

- environmental conditions at the installation location requires a higher explosion protection than indicated at the motor type plate.
- they are subjected to operating conditions which do not comply with the environmental conditions described above (e.g. operation under water, under extreme variations in temperature or extreme maximum temperatures is not permitted),
- the intended fields of application have not been expressly released for the motors by Bosch Rexroth. Please be absolutely sure to observe the statements made in the general safety instructions.

3 Safety Instructions for Electric Drives and Controls

3.1 Introduction

Read these instructions before the initial startup of the equipment in order to eliminate the risk of bodily harm or material damage. Follow these safety instructions at all times.

Do not attempt to install or start up this equipment without first reading all documentation provided with the product. Read and understand these safety instructions and all user documentation of the equipment prior to working with the equipment at any time. If you do not have the user documentation for your equipment, contact your local Bosch Rexroth representative to send this documentation immediately to the person or persons responsible for the safe operation of this equipment.

If the equipment is resold, rented or transferred or passed on to others, then these safety instructions must be delivered with the equipment.



WARNING

Improper use of this equipment, failure to follow the safety instructions in this document or tampering with the product, including disabling of safety devices, may result in material damage, bodily harm, electric shock or even death!

3.2 Explanations

The safety instructions describe the following degrees of hazard seriousness in compliance with ANSI Z535. The degree of hazard seriousness informs about the consequences resulting from non-compliance with the safety instructions.

Warning symbol with signal word	Degree of hazard seriousness according to ANSI
 DANGER	Death or severe bodily harm will occur.
 WARNING	Death or severe bodily harm may occur.
 CAUTION	Bodily harm or material damage may occur.

Fig. 3-1: Hazard classification (according to ANSI Z535)

3.3 Hazards by Improper Use



DANGER

**High voltage and high discharge current!
Danger to life or severe bodily harm by electric shock!**



DANGER

Dangerous movements! Danger to life, severe bodily harm or material damage by unintentional motor movements!



WARNING

High electrical voltage due to wrong connections! Danger to life or bodily harm by electric shock!



WARNING

Health hazard for persons with heart pacemakers, metal implants and hearing aids in proximity to electrical equipment!



CAUTION

Surface of machine housing could be extremely hot! Danger of injury! Danger of burns!



CAUTION

Risk of injury due to improper handling! Bodily harm caused by crushing, shearing, cutting and mechanical shock or incorrect handling of pressurized systems!



CAUTION

Risk of injury due to incorrect handling of batteries!

3.4 General Information

- Bosch Rexroth AG is not liable for damages resulting from failure to observe the warnings provided in this documentation.
- Read the operating, maintenance and safety instructions in your language before starting up the machine. If you find that you cannot completely understand the documentation for your product, please ask your supplier to clarify.
- Proper and correct transport, storage, assembly and installation as well as care in operation and maintenance are prerequisites for optimal and safe operation of this equipment.
- Only persons who are trained and qualified for the use and operation of the equipment may work on this equipment or within its proximity.
 - The persons are qualified if they have sufficient knowledge of the assembly, installation and operation of the equipment as well as an understanding of all warnings and precautionary measures noted in these instructions.
 - Furthermore, they must be trained, instructed and qualified to switch electrical circuits and equipment on and off in accordance with technical safety regulations, to ground them and to mark them according to the requirements of safe work practices. They must have adequate safety equipment and be trained in first aid.
- Only use spare parts and accessories approved by the manufacturer.
- Follow all safety regulations and requirements for the specific application as practiced in the country of use.
- The equipment is designed for installation in industrial machinery.
- The ambient conditions given in the product documentation must be observed.
- Use only safety features and applications that are clearly and explicitly approved in the Project Planning Manual.
For example, the following areas of use are not permitted: construction cranes, elevators used for people or freight, devices and vehicles to transport people, medical applications, refinery plants, transport of hazardous goods, nuclear applications, applications sensitive to high frequency, mining, food processing, control of protection equipment (also in a machine).
- The information given in the documentation of the product with regard to the use of the delivered components contains only examples of applications and suggestions.
The machine and installation manufacturer must
 - make sure that the delivered components are suited for his individual application and check the information given in this documentation with regard to the use of the components,
 - make sure that his application complies with the applicable safety regulations and standards and carry out the required measures, modifications and complements.
- Startup of the delivered components is only permitted once it is sure that the machine or installation in which they are installed complies with the national regulations, safety specifications and standards of the application.

- Operation is only permitted if the national EMC regulations for the application are met.
The instructions for installation in accordance with EMC requirements can be found in the documentation "EMC in Drive and Control Systems".
The machine or installation manufacturer is responsible for compliance with the limiting values as prescribed in the national regulations.
- Technical data, connections and operational conditions are specified in the product documentation and must be followed at all times.

3.5 Protection Against Contact with Electrical Parts

Note: This section refers to equipment and drive components with voltages above 50 Volts.

Touching live parts with voltages of 50 Volts and more with bare hands or conductive tools or touching ungrounded housings can be dangerous and cause electric shock. In order to operate electrical equipment, certain parts must unavoidably have dangerous voltages applied to them.



DANGER

High electrical voltage! Danger to life, severe bodily harm by electric shock!

- ⇒ Only those trained and qualified to work with or on electrical equipment are permitted to operate, maintain or repair this equipment.
 - ⇒ Follow general construction and safety regulations when working on high voltage installations.
 - ⇒ Before switching on power the ground wire must be permanently connected to all electrical units according to the connection diagram.
 - ⇒ Do not operate electrical equipment at any time, even for brief measurements or tests, if the ground wire is not permanently connected to the points of the components provided for this purpose.
 - ⇒ Before working with electrical parts with voltage higher than 50 V, the equipment must be disconnected from the mains voltage or power supply. Make sure the equipment cannot be switched on again unintended.
 - ⇒ The following should be observed with electrical drive and filter components:
 - ⇒ Wait five (5) minutes after switching off power to allow capacitors to discharge before beginning to work. Measure the voltage on the capacitors before beginning to work to make sure that the equipment is safe to touch.
 - ⇒ Never touch the electrical connection points of a component while power is turned on.
 - ⇒ Install the covers and guards provided with the equipment properly before switching the equipment on. Prevent contact with live parts at any time.
 - ⇒ A residual-current-operated protective device (RCD) must not be used on electric drives! Indirect contact must be prevented by other means, for example, by an overcurrent protective device.
 - ⇒ Electrical components with exposed live parts and uncovered high voltage terminals must be installed in a protective housing, for example, in a control cabinet.
-

To be observed with electrical drive and filter components:



DANGER

**High electrical voltage on the housing!
High leakage current! Danger to life, danger of
injury by electric shock!**

- ⇒ Connect the electrical equipment, the housings of all electrical units and motors permanently with the safety conductor at the ground points before power is switched on. Look at the connection diagram. This is even necessary for brief tests.
- ⇒ Connect the safety conductor of the electrical equipment always permanently and firmly to the supply mains. Leakage current exceeds 3.5 mA in normal operation.
- ⇒ Use a copper conductor with at least 10 mm² cross section over its entire course for this safety conductor connection!
- ⇒ Prior to startups, even for brief tests, always connect the protective conductor or connect with ground wire. Otherwise, high voltages can occur on the housing that lead to electric shock.

3.6 Protection Against Electric Shock by Protective Low Voltage (PELV)

All connections and terminals with voltages between 0 and 50 Volts on Rexroth products are protective low voltages designed in accordance with international standards on electrical safety.



WARNING

**High electrical voltage due to wrong
connections! Danger to life, bodily harm by
electric shock!**

- ⇒ Only connect equipment, electrical components and cables of the protective low voltage type (PELV = Protective Extra Low Voltage) to all terminals and clamps with voltages of 0 to 50 Volts.
- ⇒ Only electrical circuits may be connected which are safely isolated against high voltage circuits. Safe isolation is achieved, for example, with an isolating transformer, an opto-electronic coupler or when battery-operated.

3.7 Protection Against Dangerous Movements

Dangerous movements can be caused by faulty control of the connected motors. Some common examples are:

- improper or wrong wiring of cable connections
- incorrect operation of the equipment components
- wrong input of parameters before operation
- malfunction of sensors, encoders and monitoring devices
- defective components
- software or firmware errors

Dangerous movements can occur immediately after equipment is switched on or even after an unspecified time of trouble-free operation.

The monitoring in the drive components will normally be sufficient to avoid faulty operation in the connected drives. Regarding personal safety, especially the danger of bodily injury and material damage, this alone cannot be relied upon to ensure complete safety. Until the integrated monitoring functions become effective, it must be assumed in any case that faulty drive movements will occur. The extent of faulty drive movements depends upon the type of control and the state of operation.

**DANGER****Dangerous movements! Danger to life, risk of injury, severe bodily harm or material damage!**

- ⇒ Ensure personal safety by means of qualified and tested higher-level monitoring devices or measures integrated in the installation. Unintended machine motion is possible if monitoring devices are disabled, bypassed or not activated.
- ⇒ Pay attention to unintended machine motion or other malfunction in any mode of operation.

- ⇒ Keep free and clear of the machine's range of motion and moving parts. Possible measures to prevent people from accidentally entering the machine's range of motion:
 - use safety fences
 - use safety guards
 - use protective coverings
 - install light curtains or light barriers
- ⇒ Fences and coverings must be strong enough to resist maximum possible momentum, especially if there is a possibility of loose parts flying off.
- ⇒ Mount the emergency stop switch in the immediate reach of the operator. Verify that the emergency stop works before startup. Don't operate the machine if the emergency stop is not working.
- ⇒ Isolate the drive power connection by means of an emergency stop circuit or use a starting lockout to prevent unintentional start.
- ⇒ Make sure that the drives are brought to a safe standstill before accessing or entering the danger zone. Safe standstill can be achieved by switching off the power supply contactor or by safe mechanical locking of moving parts.
- ⇒ Secure vertical axes against falling or dropping after switching off the motor power by, for example:
 - mechanically securing the vertical axes
 - adding an external braking/ arrester/ clamping mechanism
 - ensuring sufficient equilibration of the vertical axes

The standard equipment motor brake or an external brake controlled directly by the drive controller are not sufficient to guarantee personal safety!

- ⇒ Disconnect electrical power to the equipment using a master switch and secure the switch against reconnection for:
 - maintenance and repair work
 - cleaning of equipment
 - long periods of discontinued equipment use
 - ⇒ Prevent the operation of high-frequency, remote control and radio equipment near electronics circuits and supply leads. If the use of such equipment cannot be avoided, verify the system and the installation for possible malfunctions in all possible positions of normal use before initial startup. If necessary, perform a special electromagnetic compatibility (EMC) test on the installation.
-

3.8 Protection Against Magnetic and Electromagnetic Fields During Operation and Mounting

Magnetic and electromagnetic fields generated near current-carrying conductors and permanent magnets in motors represent a serious health hazard to persons with heart pacemakers, metal implants and hearing aids.



WARNING

Health hazard for persons with heart pacemakers, metal implants and hearing aids in proximity to electrical equipment!

- ⇒ Persons with heart pacemakers, hearing aids and metal implants are not permitted to enter the following areas:
 - Areas in which electrical equipment and parts are mounted, being operated or started up.
 - Areas in which parts of motors with permanent magnets are being stored, operated, repaired or mounted.
 - ⇒ If it is necessary for a person with a heart pacemaker to enter such an area, then a doctor must be consulted prior to doing so. Heart pacemakers that are already implanted or will be implanted in the future, have a considerable variation in their electrical noise immunity. Therefore there are no rules with general validity.
 - ⇒ Persons with hearing aids, metal implants or metal pieces must consult a doctor before they enter the areas described above. Otherwise, health hazards will occur.
-

3.9 Protection Against Contact with Hot Parts



CAUTION

**Housing surfaces could be extremely hot!
Danger of injury! Danger of burns!**

- ⇒ Do not touch housing surfaces near sources of heat!
Danger of burns!
- ⇒ After switching the equipment off, wait at least ten (10) minutes to allow it to cool down before touching it.
- ⇒ Do not touch hot parts of the equipment, such as housings with integrated heat sinks and resistors.
Danger of burns!



WARNING

**Burning via hot surface with temperatures over
100°C**

- ⇒ Do not touch the hot motor housing! Risk of burning
- ⇒ Touch the motor only after cooling! A cooling up to 140 minutes can be necessary! The stated thermal time constant in the technical data is a measure for the necessary cooling
- ⇒ Do not work on hot surfaces.
- ⇒ Use safety gloves

3.10 Protection During Handling and Mounting

Under certain conditions, incorrect handling and mounting of parts and components may cause injuries.



CAUTION

Risk of injury by incorrect handling! Bodily harm caused by crushing, shearing, cutting and mechanical shock!

- ⇒ Observe general installation and safety instructions with regard to handling and mounting.
- ⇒ Use appropriate mounting and transport equipment.
- ⇒ Take precautions to avoid pinching and crushing.
- ⇒ Use only appropriate tools. If specified by the product documentation, special tools must be used.
- ⇒ Use lifting devices and tools correctly and safely.
- ⇒ For safe protection wear appropriate protective clothing, e.g. safety glasses, safety shoes and safety gloves.
- ⇒ Never stand under suspended loads.
- ⇒ Clean up liquids from the floor immediately to prevent slipping.

3.11 Battery Safety

Batteries contain reactive chemicals in a solid housing. Inappropriate handling may result in injuries or material damage.



CAUTION

Risk of injury by incorrect handling!

- ⇒ Do not attempt to reactivate discharged batteries by heating or other methods (danger of explosion and cauterization).
- ⇒ Never charge non-chargeable batteries (danger of leakage and explosion).
- ⇒ Never throw batteries into a fire.
- ⇒ Do not dismantle batteries.
- ⇒ Do not damage electrical components installed in the equipment.

Note: Be aware of environmental protection and disposal! The batteries contained in the product should be considered as hazardous material for land, air and sea transport in the sense of the legal requirements (danger of explosion). Dispose batteries separately from other waste. Observe the legal requirements in the country of installation.

3.12 Protection Against Pressurized Systems

Certain motors and drive controllers, corresponding to the information in the respective Project Planning Manual, must be provided with pressurized media, such as compressed air, hydraulic oil, cooling fluid and cooling lubricant supplied by external systems. Incorrect handling of the supply and connections of pressurized systems can lead to injuries or accidents. In these cases, improper handling of external supply systems, supply lines or connections can cause injuries or material damage.



CAUTION

Danger of injury by incorrect handling of pressurized systems !

- ⇒ Do not attempt to disassemble, to open or to cut a pressurized system (danger of explosion).
- ⇒ Observe the operation instructions of the respective manufacturer.
- ⇒ Before disassembling pressurized systems, release pressure and drain off the fluid or gas.
- ⇒ Use suitable protective clothing (for example safety glasses, safety shoes and safety gloves)
- ⇒ Remove any fluid that has leaked out onto the floor immediately.

Note: Environmental protection and disposal! The media used in the operation of the pressurized system equipment may not be environmentally compatible. Media that are damaging the environment must be disposed separately from normal waste. Observe the legal requirements in the country of installation.

Notes

4 Technical data

4.1 Description

The speed-torque curves and the technical data are specified for different motor overtemperatures.

Note: When selecting the technical data, observe the temperatures specified!

Assembling and Measuring of the characteristic curve

The motor data and characteristic curves are determined using MKE motors under the following conditions:

- Environmental temperature max. 40°C
- Insulated structure (aluminum flange)
- If motors with the optional holding brake are concerned, the data are always specified for motors **with** holding brake.
- Motors with radial shaft sealing ring

Operating Modes

Rexroth Indramat motors are documented according to the test criteria and measuring methods of EN 60034-1. The characteristic curves specified correspond to the operating modes S1 or S6.

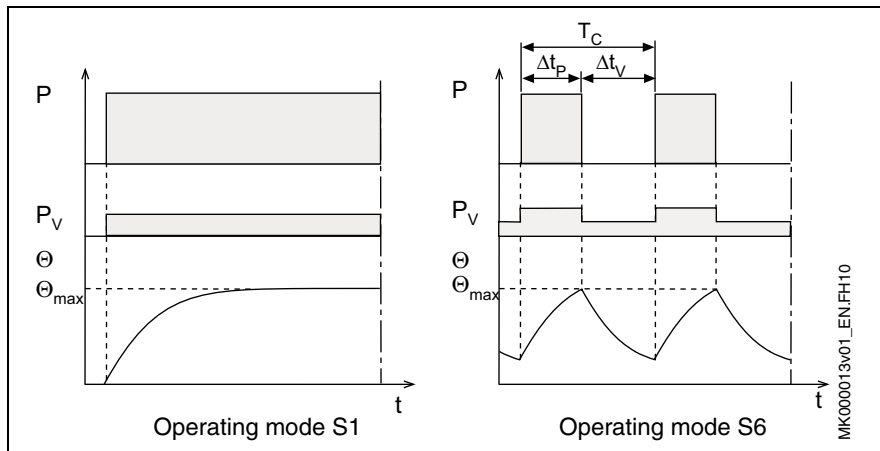

- P: Load
 P_V: Electric losses
 Θ: Temperature
 Θ_{max}: Highest temperature (motor housing)
 t: Time
 T_C: Cycle duration
 Δt_P: Operating time with constant load
 Δt_V: Idle time

Fig. 4-1: Operating modes according to EN 60034-1: 1998

ON time

The operating mode S6 is supplemented by specification of the ON time (ED) in %. The ON time is calculated with the following formula:

$$ED = \frac{\Delta t_P}{T_C} \cdot 100\%$$

- ED: Cyclic duration factor in %
 T_C: Cycle duration
 Δt_P: Operating time with constant load

Fig. 4-2: Cyclic duration factor

The values specified in the documentation have been determined on the basis of the following parameters:

- Cycle duration: 15 min
 Cyclic duration factor (ED): 25%

Note: If applicable, conditions deviating therefrom are marked accordingly.

Definition of Parameters

Electric parameters

Characteristic motor speed n_K	With a DC link voltage of 540 V _{DC} and at the characteristic speed, the continuous torque that can be output is approx. ½ continuous torque at standstill.
Continuous torque at standstill M_{dN}	The continuous torque that can be output at the motor output shaft at a speed of $n = 0$.
Continuous current at standstill I_{dN}	Phase current (crest value) of the motor required for the continuous torque at standstill M_{dN} at a speed of $n = 0$.
Peak current I_{max}	Maximum, briefly permissible phase current (crest value) of the motor without adverse affect on the permanent magnet circuit of the motor.
Torque constant at 20 °C K_M	Ratio of the increase in torque to the motor phase current (crest value) at a motor temperature of 20 °C. Unit: (Nm/A). Applicable up to approx. $i = 2 \times I_{dN}$.
Voltage constant at 20 °C $K_{E(eff)}$	Root-mean-square value of the induced motor voltage at a motor temperature of 20 °C and 1000 revolutions per minute. Unit: (V/1000 min ⁻¹).
Winding resistance at 20 °C R_{12}	Winding resistance measured between two phases in ohms (Ω).
Winding inductivity L_{12}	Inductivity measured between two phases in (mH).
Number of pole pairs p	Number of pole pairs of the motor.
Maximum speed n_{max}	Maximum permissible speed of the motor. Limiting factors can have mechanical (centrifugal forces, bearing stress) or electrical (DC link voltage) causes.
Theoretical maximum torque M_{max}	Maximum torque that can be output for approx. 400 ms at a peak current of I_{max} (guaranteed value which, owing to production tolerances, may be higher by 20%). The achievable maximum torque depends on the drive controller used. Only the maximum torques M_{max} specified in the selection lists for the motor-controller combination are binding.
Moment of inertia of the rotor J_M	Moment of inertia of the rotor without the optional holding brake. Unit (kgm ²).
Mass m_M	Motor mass without the optional holding brake and optional motor fan, specified in kg.
Thermal time constant T_{th}	Time of the temperature rise to 63% of the final temperature motor housing with the motor loaded with the permissible S1 continuous torque. The thermal time constant is defined by the type of cooling used.

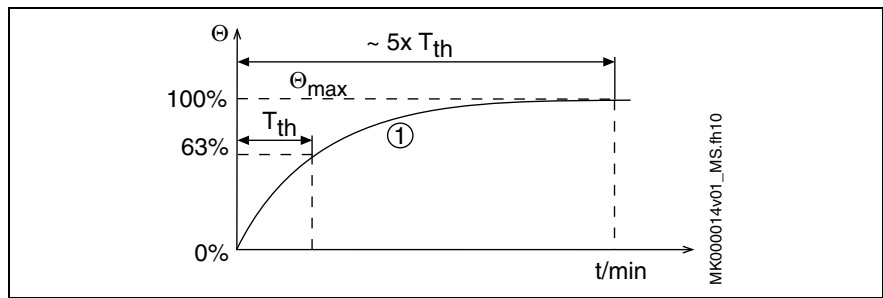

- (1): Course of the motor housing temperature over time
 Θ_{\max} : Highest temperature (motor housing)
 T_{th} : Thermal time constant

Fig. 4-3: Thermal time constant

Sample Curve

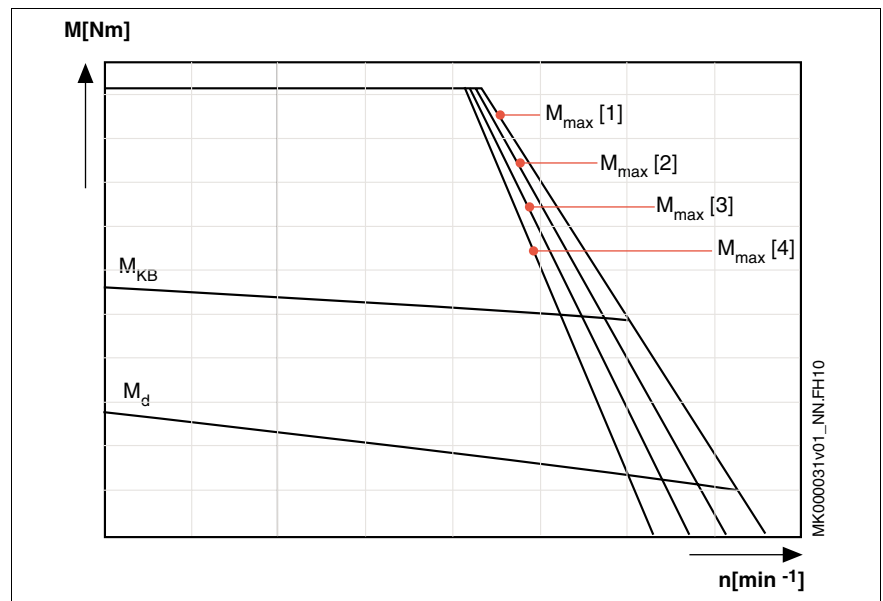

Thermal limit curves

M_d : S1 continuous operation curve of the motor (according to EN 60034-1; 1998), natural convection

M_{KB} : S6 intermittent operation curve with a motor ON time of 25% (according to EN 60034-1; 1998). The maximum cycle duration is 15 min.

$[M_{\max}]$: Corresponds to the theoretically possible maximum torque of the motor. The value can be limited by the drive controller.

[1]-[4]: **Characteristic voltage limit curves.** When a speed at the safe commutation limit is reached, the voltage limit curve limits the available maximum torque M_{\max} . The maximum motor speed is determined by the DC link voltage used. There are separate characteristic curves for the various drive controllers in connection with the power supply unit and the supply voltage used.

[1]: HDS to HVR

[2]: HDS to HVE or DKCxx.3 with a power connection of 3 x AC 480 V

[3]: HDS to HVE or DKCxx.3 with a power connection of 3 x AC 440 V

[4]: HDS to HVE or DKCxx.3 with a power connection of 3 x AC 400 V

Fig. 4-4: Sample curves

Notes

4.2 Technical Data MKE037

Technical data sheet and characteristic curves

Winding	Symbol	Unit	MKE037B			
			144			
Characteristic speed	n_K	min^{-1}	9000			
Continuous torque at standstill	M_{dN}	Nm	0.9 (0.8)			
Continuous current at standstill	I_{dN}	A	4.7 (4.2)			
Max. torque (theoretical)	M_{max}	Nm	4.0			
Max. voltage	I_{max}	A	21.2			
Constant torque at 20°C	K_M	Nm/A	0.21			
Constant voltage at 20°C	K_E	$\text{V}/1000\text{min}^{-1}$	18.2			
Winding resistance at 20°C	R_{12}	Ohm	2.7			
Winding inductivity	L_{12}	mH	3.7			
Number of pole pairs	p		3			
Moment of inertia of rotor without brake	J_{oB}	kgm^2	0.00003			
Moment of inertia of rotor with brake	J_{mB}	kgm^2	0.000037			
Thermal time constant	T_{th}	min	15			
Max. torque (theoretical)	n_{max}	min^{-1}	9000			
Mass without brake	M_{oB}	kg	2.5			
Mass with brake	M_{mB}	kg	2.8			
Middle acoustic pressure	L_p	dB(A)	> 75			
Storage and transport temperature	T_L	°C	-20 to +80			
Environmental temp. (in operation)	T_{um}	°C	0 to 40			
Setup elevation	H	M	1000 above MSL (max. without deration)			
Protection class			IP65			
Insulation class			F (according to DIN VDE 0530 Part 1)			
Housing varnish			Prime coat black in a/w RAL 9005			

Holding brake (optional)						
Holding torque	M_4	Nm				1.0
Rated voltage (+/- 10%)	U_N	V				24.0
Rated current	I_N	A				0.4
Connection time	t_1	ms				3
Disconnection time	t_2	ms				4

Fig. 4-5: Data sheet MKE037

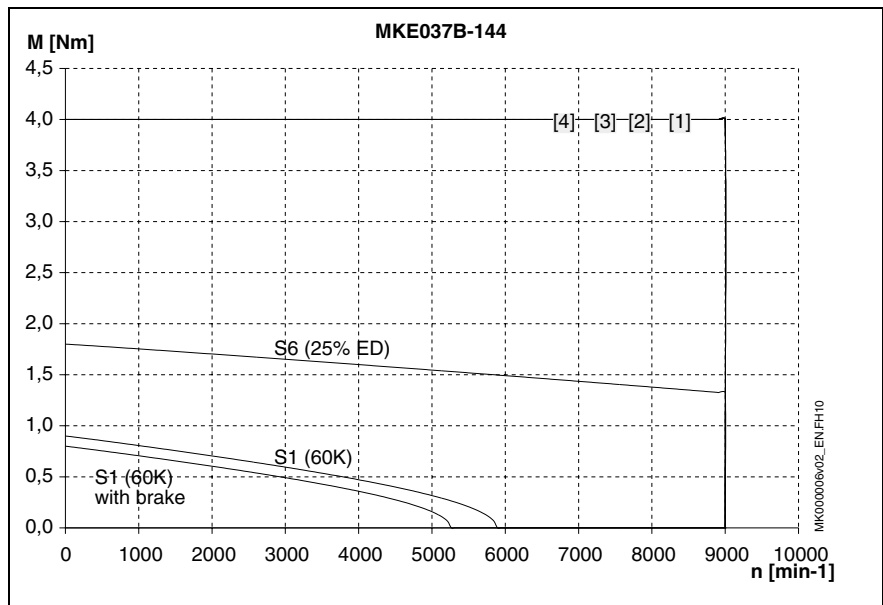

$M_{max}[1]$: IndraDrive, controlled feed 3 x AC 400V

$M_{max}[2]$: IndraDrive, uncontrolled feed 3 x AC 480V

$M_{max}[3]$: IndraDrive, uncontrolled feed 3 x AC 440V

$M_{max}[4]$: IndraDrive, uncontrolled feed 3 x AC 400V

M_d : S1 continuous operation characteristic curve; Natural conv.

M_{KB} : S6 intermitted operation characteristic curve (25% ED) max. duty cycle time 15 min.

Fig. 4-6: Speed-Torque Curves

Shaft loads

Additional information about permissible radial and axial forces see chapter "Application notes".

Radial force F_{radial} Diagram for determining the maximum permissible radial force F_{radial} .

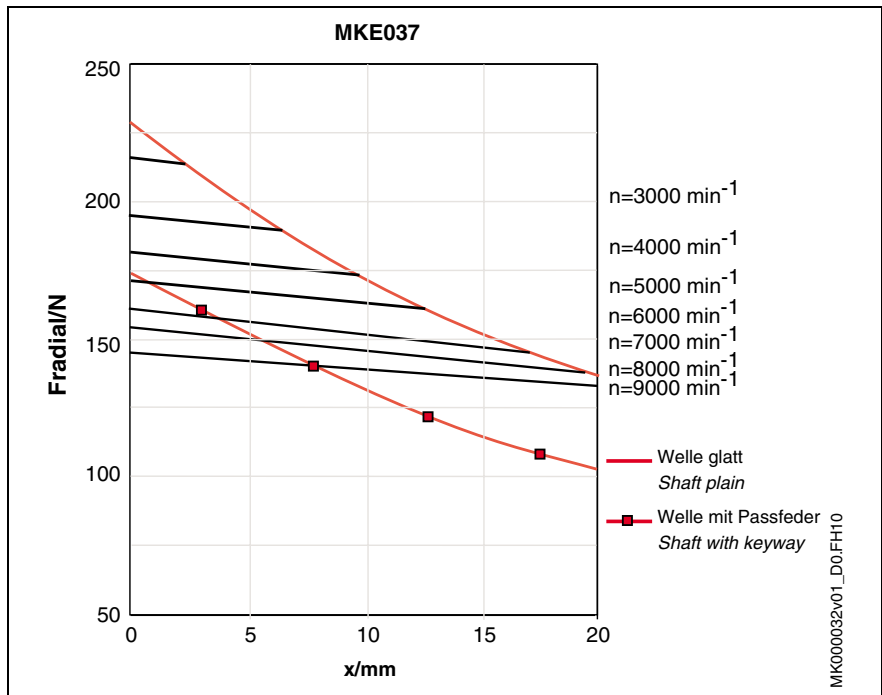

Fig. 4-7: MKE037: permissible radial force (shaft and bearing load)

Axial force F_{axial} Determine the maximum permissible axial force with the radial force shown in the diagram and the given factors of the motor size.

Motor Frame Size	Factor
MKE037B	0.58
$F_{axial} = \text{Faktor} * F_{radial}$	

Fig. 4-8: MKE037 permissible axial force

Notes

4.3 Technical Data MKE047

Technical data sheet and characteristic curves

Winding	Symbol	Unit	MKE047B			
			144			
Characteristic speed	n_K	min^{-1}	6000			
Continuous torque at standstill	M_{dN}	Nm	2.7			
Continuous current at standstill	I_{dN}	A	7.1			
Max. torque (theoretical)	M_{max}	Nm	11.3			
Max. voltage	I_{max}	A	32.0			
Constant torque at 20°C	K_M	Nm/A	0.42			
Constant voltage at 20°C	K_E	$\text{V}/1000\text{min}^{-1}$	36.3			
Winding resistance at 20°C	R_{12}	Ohm	1.8			
Winding inductivity	L_{12}	mH	5.0			
Number of pole pairs	p		4			
Moment of inertia of rotor without brake	J_{oB}	kgm^2	0.00017			
Moment of inertia of rotor with brake	J_{mB}	kgm^2	0.00018			
Thermal time constant	T_{th}	min	30			
Max. torque (theoretical)	n_{max}	min^{-1}	7000			
Mass without brake	M_{oB}	kg	5.5			
Mass with brake	M_{mB}	kg	5.8			
Middle acoustic pressure	L_p	dB(A)	> 75			
Storage and transport temperature	T_L	°C	-20 to +80			
Environmental temp. (in operation)	T_{um}	°C	0 to 40			
Setup elevation	H	M	1000 above MSL (max. without deration)			
Protection class			IP65			
Insulation class			F (according to DIN VDE 0530 Part 1)			
Housing varnish			Prime coat black in a/w RAL 9005			

Holding brake (optional)						
Holding torque	M_4	Nm				2.2
Rated voltage (+/- 10%)	U_N	V				24
Rated current	I_N	A				0.34
Connection time	t_1	ms				28
Disconnection time	t_2	ms				14

Fig. 4-9: Data sheet MKE047

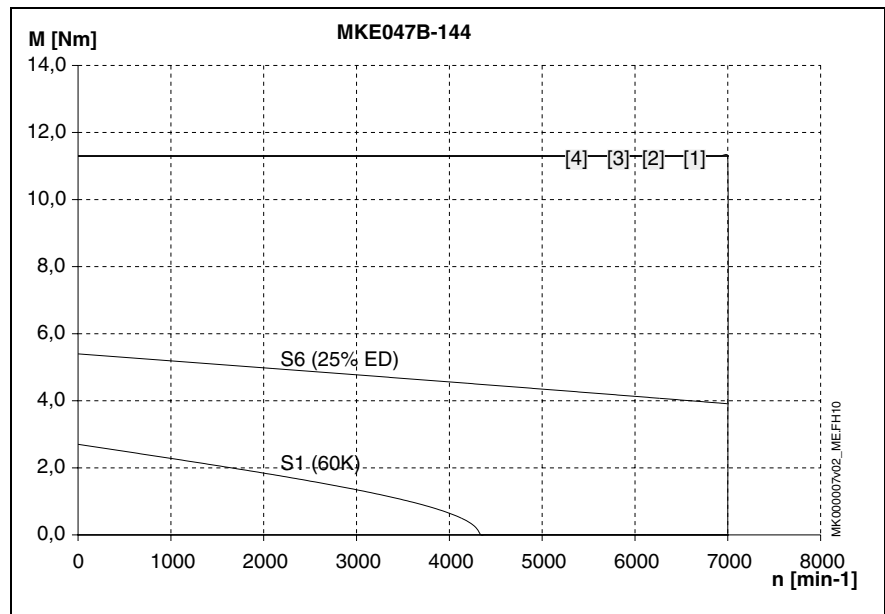

$M_{max}[1]$: IndraDrive, controlled feed 3 x AC 400V

$M_{max}[2]$: IndraDrive, uncontrolled feed 3 x AC 480V

$M_{max}[3]$: IndraDrive, uncontrolled feed 3 x AC 440V

$M_{max}[4]$: IndraDrive, uncontrolled feed 3 x AC 400V

M_d : S1 continuous operation characteristic curve; Natural conv.

M_{KB} : S6 intermitted operation characteristic curve (25% ED) max. duty cycle time 15 min.

Fig. 4-10: Speed-Torque Curves

Shaft loads

Additional information about permissible radial and axial forces see chapter "Application notes".

Radial force F_{radial} Diagram for determining the maximum permissible radial force F_{radial} .

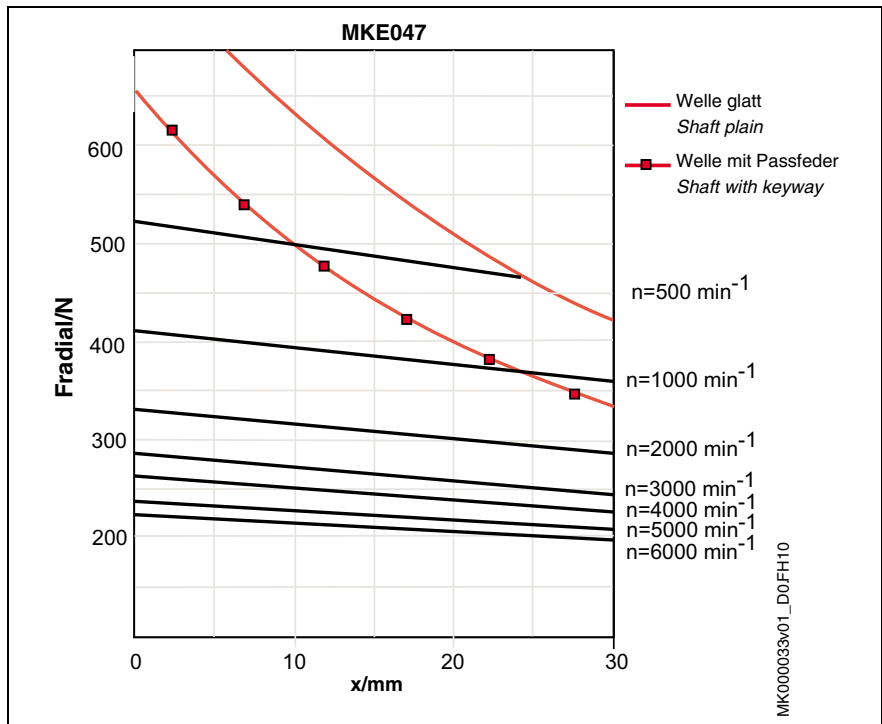

Fig. 4-11: MKE047: permissible radial force (shaft and bearing load)

Axial force F_{axial} Determine the maximum permissible axial force with the radial force shown in the diagram and the given factors of the motor size.

Motor Frame Size	Factor
MKE047B	0.44
$F_{\text{axial}} = \text{Faktor} * F_{\text{radial}}$	

Fig. 4-12: MKE047 permissible axial force

Notes

4.4 Technical Data MKE098

Data sheet and characteristic curves

Winding	Symbol	Unit	MKE098B			
			047	058		
Characteristic speed	n_K	min^{-1}	3200	4000		
Continuous torque at standstill	M_{dN}	Nm	12.0	12.0		
Continuous current at standstill	I_{dN}	A	13.9	17.5		
Max. torque (theoretical)	M_{max}	Nm	43.5	43.5		
Max. voltage	I_{max}	A	62.6	79.0		
Constant torque at 20°C	K_M	Nm/A	1.0	0.77		
Constant voltage at 20°C	K_E	$\text{V}/1000\text{min}^{-1}$	91.0	70.0		
Winding resistance at 20°C	R_{12}	Ohm	1.2	0.74		
Winding inductivity	L_{12}	mH	10.1	5.8		
Number of pole pairs	p		4	4		
Moment of inertia of rotor without brake	J_{oB}	kgm^2	0.0043	0.0043		
Moment of inertia of rotor with brake	J_{mB}	kgm^2	0.00466	0.00466		
Thermal time constant	T_{th}	min	60	60		
Max. torque (theoretical)	n_{max}	min^{-1}	4600	5000		
Mass without brake	M_{oB}	kg	18.0	18.0		
Mass with brake	M_{mB}	kg	19.1	19.1		
Middle acoustic pressure	L_p	dB(A)	63.0	63.0		
Storage and transport temperature	T_L	°C	-20 to +80			
Environmental temp. (in operation)	T_{um}	°C	0 to 40			
Setup elevation	H	M	1000 above MSL (max. without deration)			
Protection class			IP65			
Insulation class			F (according to DIN VDE 0530 Part 1)			
Housing varnish			Prime coat black in a/w RAL 9005			

Holding brake (optional)					
Holding torque	M_4	Nm			11.0
Rated voltage (+/- 10%)	U_N	V			24.0
Rated current	I_N	A			0.71
Connection time	t_1	ms			30
Disconnection time	t_2	ms			11

Fig. 4-13: Data sheet MKE098B

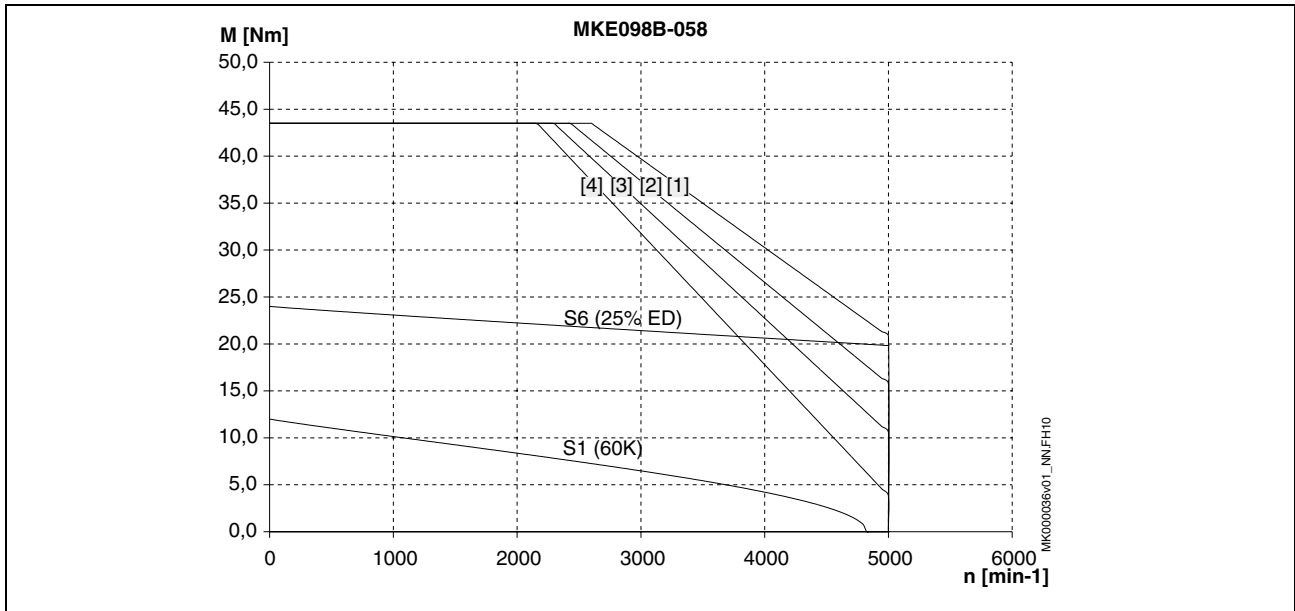
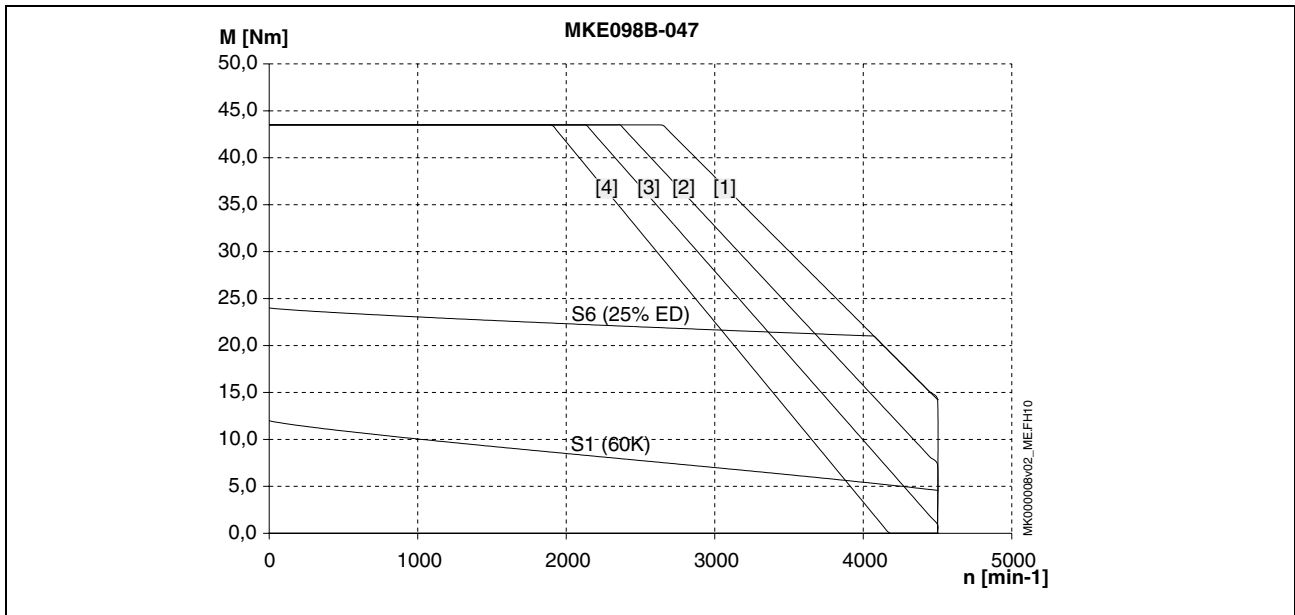

- [S1_{natural}]: M_{dN} Natural conv. (S1 continuous operation)
- [S6_{25%ED}]: M_{KB} (S6 intermittent operation, 25% ED)
- $M_{max}[1]$: IndraDrive, controlled feed 3 x AC 400V
- $M_{max}[2]$: IndraDrive, uncontrolled feed 3 x AC 480V
- $M_{max}[3]$: IndraDrive, uncontrolled feed 3 x AC 440V
- $M_{max}[4]$: IndraDrive, uncontrolled feed 3 x AC 400V

Fig. 4-14: Speed-Torque Curves

Shaft loads

Additional information about permissible radial and axial forces see chapter "Application notes".

Radial force F_{radial} Diagram for determining the maximum permissible radial force F_{radial} .

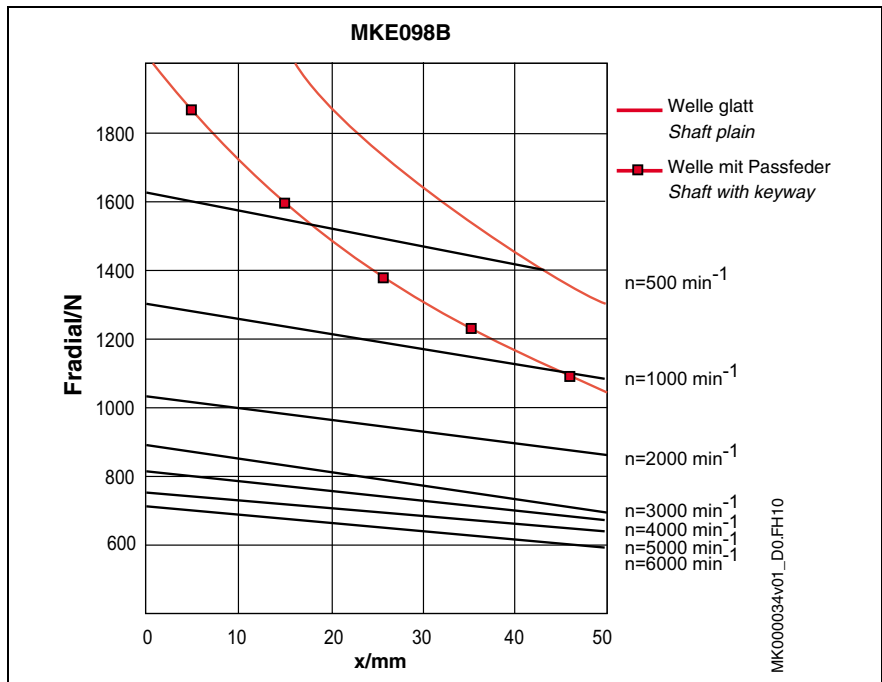

Fig. 4-15: MKE098: permissible radial force (shaft and bearing load)

Axial force F_{axial} Determine the maximum permissible axial force with the radial force shown in the diagram and the given factors of the motor size.

Motor Frame Size	Factor
MKE098B	0.33
$F_{axial} = \text{Faktor} * F_{radial}$	

Fig. 4-16: MKE098B permissible axial force

Notes

4.5 Technical Data MKE118

Data sheet and characteristic curves

Winding	Symbol	Unit	MKE118B			
			024	058		
Characteristic speed	n_K	min^{-1}	2000	4000		
Continuous torque at standstill	M_{dN}	Nm	28.0	28.0		
Continuous current at standstill	I_{dN}	A	21.7	40.1		
Max. torque (theoretical)	M_{max}	Nm	102.0	102.0		
Max. voltage	I_{max}	A	97.7	180.5		
Constant torque at 20°C	K_M	Nm/A	1.50	0.81		
Constant voltage at 20°C	K_E	$\text{V}/1000\text{min}^{-1}$	130.0	70.0		
Winding resistance at 20°C	R12	Ohm	0.58	0.17		
Winding inductivity	L12	mH	7.6	2.2		
Number of pole pairs	p		4	4		
Moment of inertia of rotor without brake	J_{oB}	kgm^2	0.01940	0.01940		
Moment of inertia of rotor with brake	J_{mB}	kgm^2	0.01976	0.01976		
Thermal time constant	T_{th}	min	90	90		
Max. torque (theoretical)	n_{max}	min^{-1}	4000	4500		
Mass without brake	M_{oB}	kg	44.0	44.0		
Mass with brake	M_{mB}	kg	45.1	45.1		
Middle acoustic pressure	L_p	dB(A)	63	63		
Storage and transport temperature	T_L	°C	-20 to +80			
Environmental temp. (in operation)	T_{um}	°C	0 to 40			
Setup elevation	H	M	1000 above MSL (max. without deration)			
Protection class			IP65			
Insulation class			F (according to DIN VDE 0530 Part 1)			
Housing varnish			Prime coat black in a/w RAL 9005			

Holding brake (optional)			Holding brake 1
Holding torque	M_4	Nm	22.0
Rated voltage (+/- 10%)	U_N	V	24.0
Rated current	I_N	A	0.71
Connection time	t_1	ms	25
Disconnection time	t_2	ms	50

Fig. 4-17: Data sheet MKE118B

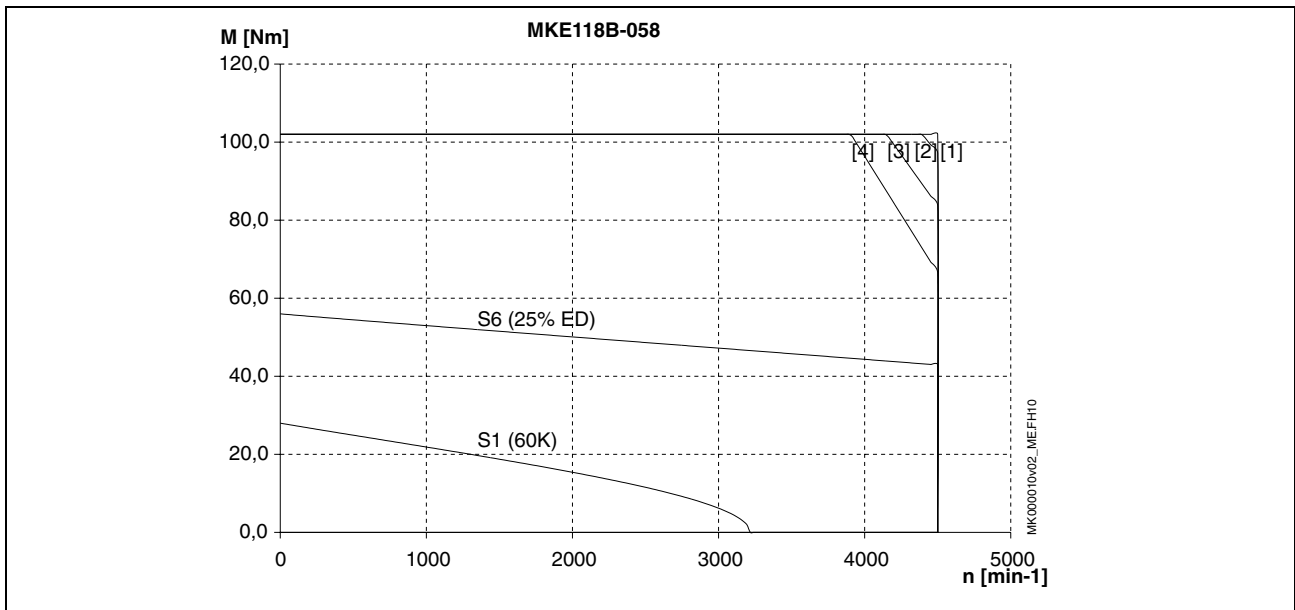
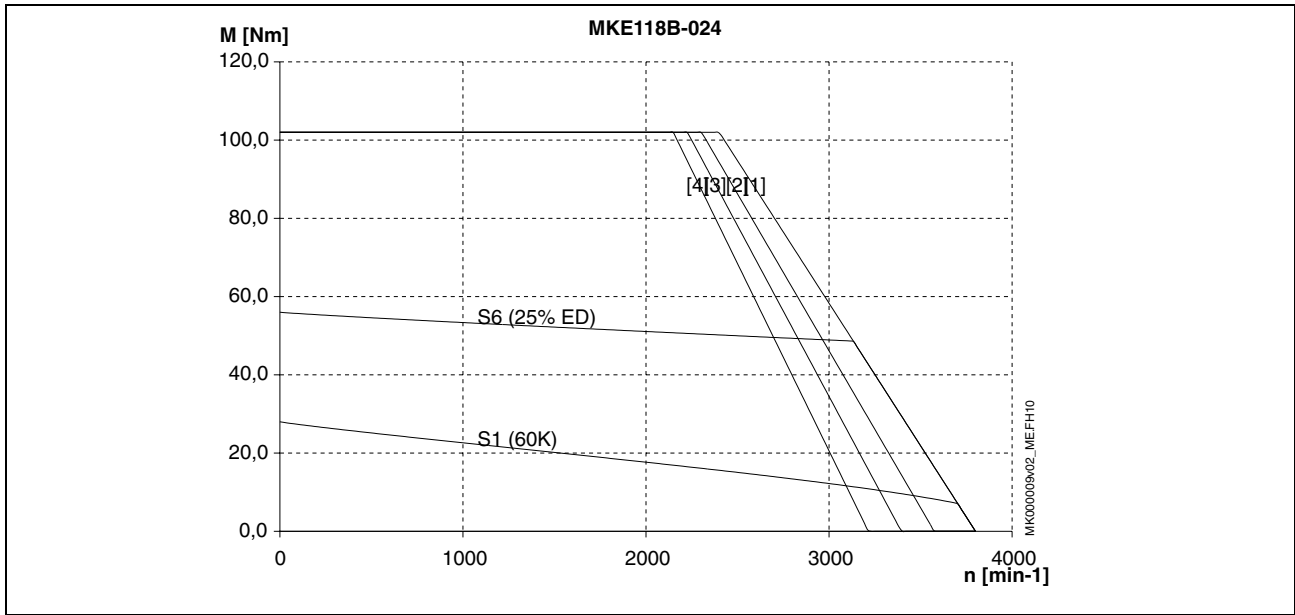

- [S1_{natural}]: M_{dN} Natural conv. (S1 continuous operation)
- [S6_{25%ED}]: M_{KB} (S6 intermittent operation, 25% ED)
- $M_{max}[1]$: IndraDrive, controlled feed 3 x AC 400V
- $M_{max}[2]$: IndraDrive, uncontrolled feed 3 x AC 480V
- $M_{max}[3]$: IndraDrive, uncontrolled feed 3 x AC 440V
- $M_{max}[4]$: IndraDrive, uncontrolled feed 3 x AC 400V

Abb. 4-1: Speed-Torque Curves

Winding	Symbol	Unit	MKE118D		
			012	027	035
Characteristic speed	n_K	min^{-1}		2000	3000
Continuous torque at standstill	M_{dN}	Nm		48.0	48.0
Continuous current at standstill	I_{dN}	A		31.3	42.2
Max. torque (theoretical)	$M_{I_{max}}$	Nm		187.0	187.0
Max. voltage	I_{max}	A		140.9	190.0
Constant torque at 20°C	K_M	Nm/A		1.78	1.32
Constant voltage at 20°C	K_E	$\text{V}/1000\text{min}^{-1}$		154.5	114.5
Winding resistance at 20°C	R12	Ohm		0.35	0.21
Winding inductivity	L12	mH		5.7	3.2
Number of pole pairs	p			4	4
Moment of inertia of rotor without brake	J_{oB}	kgm^2		0.03620	0.03620
Moment of inertia of rotor with brake	J_{mB}	kgm^2		0.03938	0.03938
Thermal time constant	T_{th}	min		90	90
Max. torque (theoretical)	n_{max}	min^{-1}		3000	3000
Mass without brake	M_{oB}	kg		65.0	65.0
Mass with brake	M_{mB}	kg		69.1	69.1
Middle acoustic pressure	L_p	dB(A)		63	63
Storage and transport temperature	T_L	°C	-20 to +80		
Environmental temp. (in operation)	T_{um}	°C	0 to 40		
Setup elevation	H	M	1000 above MSL (max. without deration)		
Protection class			IP65		
Insulation class			F (according to DIN VDE 0530 Part 1)		
Housing varnish			Prime coat black in a/w RAL 9005		

Holding brake (optional)			Holding brake 3
Holding torque	M_4	Nm	70.0
Rated voltage (+/- 10%)	U_N	V	24.0
Rated current	I_N	A	1.29
Connection time	t_1	ms	53
Disconnection time	t_2	ms	97

Fig. 4-17: Data sheet MKE118D

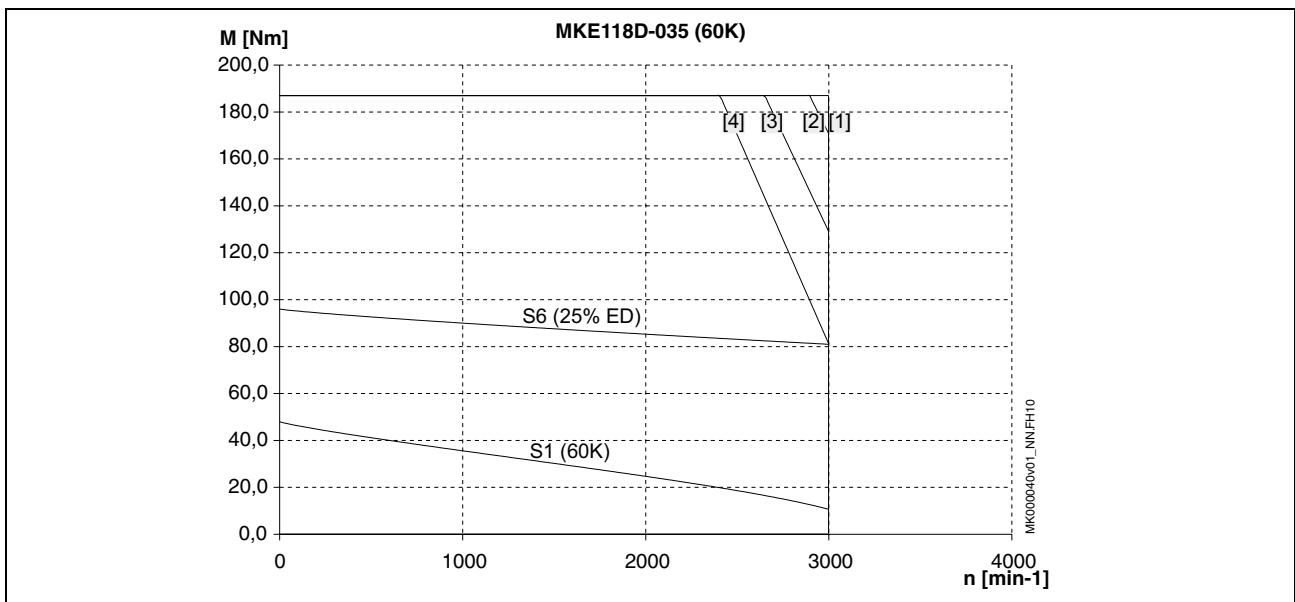
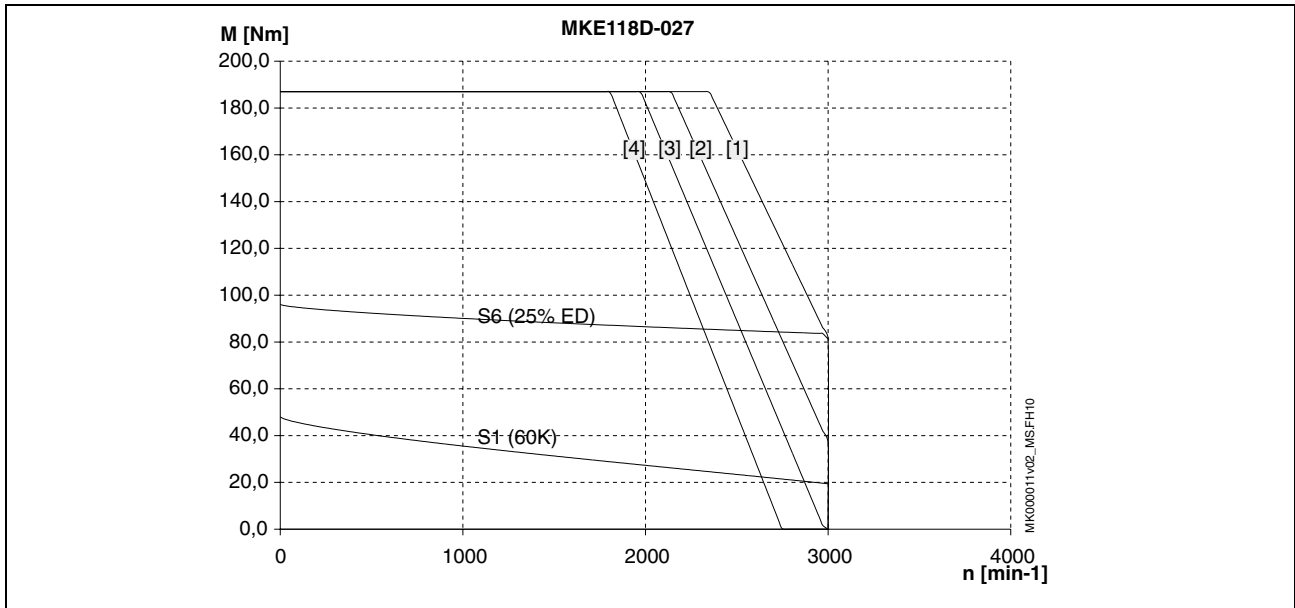

- [S1_{natural}]: M_{dN} Natural conv. (S1 continuous operation)
- [S6_{25%ED}]: M_{KB} (S6 intermittent operation, 25% ED)
- M_{max}[1]: IndraDrive, controlled feed 3 x AC 400V
- M_{max}[2]: IndraDrive, uncontrolled feed 3 x AC 480V
- M_{max}[3]: IndraDrive, uncontrolled feed 3 x AC 440V
- M_{max}[4]: IndraDrive, uncontrolled feed 3 x AC 400V

Abb. 4-2: Speed-Torque Curves

Shaft loads

Additional information about permissible radial and axial forces see chapter "Application notes".

Radial force F_{radial}

Diagram for determining the maximum permissible radial force F_{radial} .

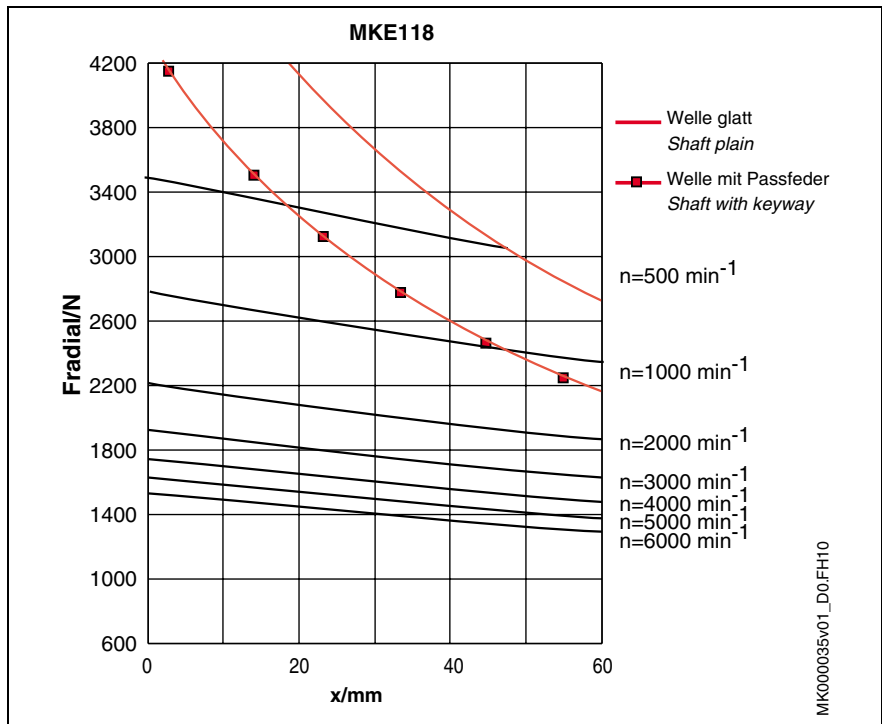

Fig. 4-19: MKE118: permissible radial force (shaft and bearing load)

Axial force F_{axial}

Determine the maximum permissible axial force with the radial force shown in the diagram and the given factors of the motor size.

Motor Frame Size	Factor
MKE118B	0.33
MKE118D	
$F_{axial} = \text{Faktor} * F_{radial}$	

Fig. 4-20: MKE118 permissible axial force

5 Dimensional Details

5.1 Size 037

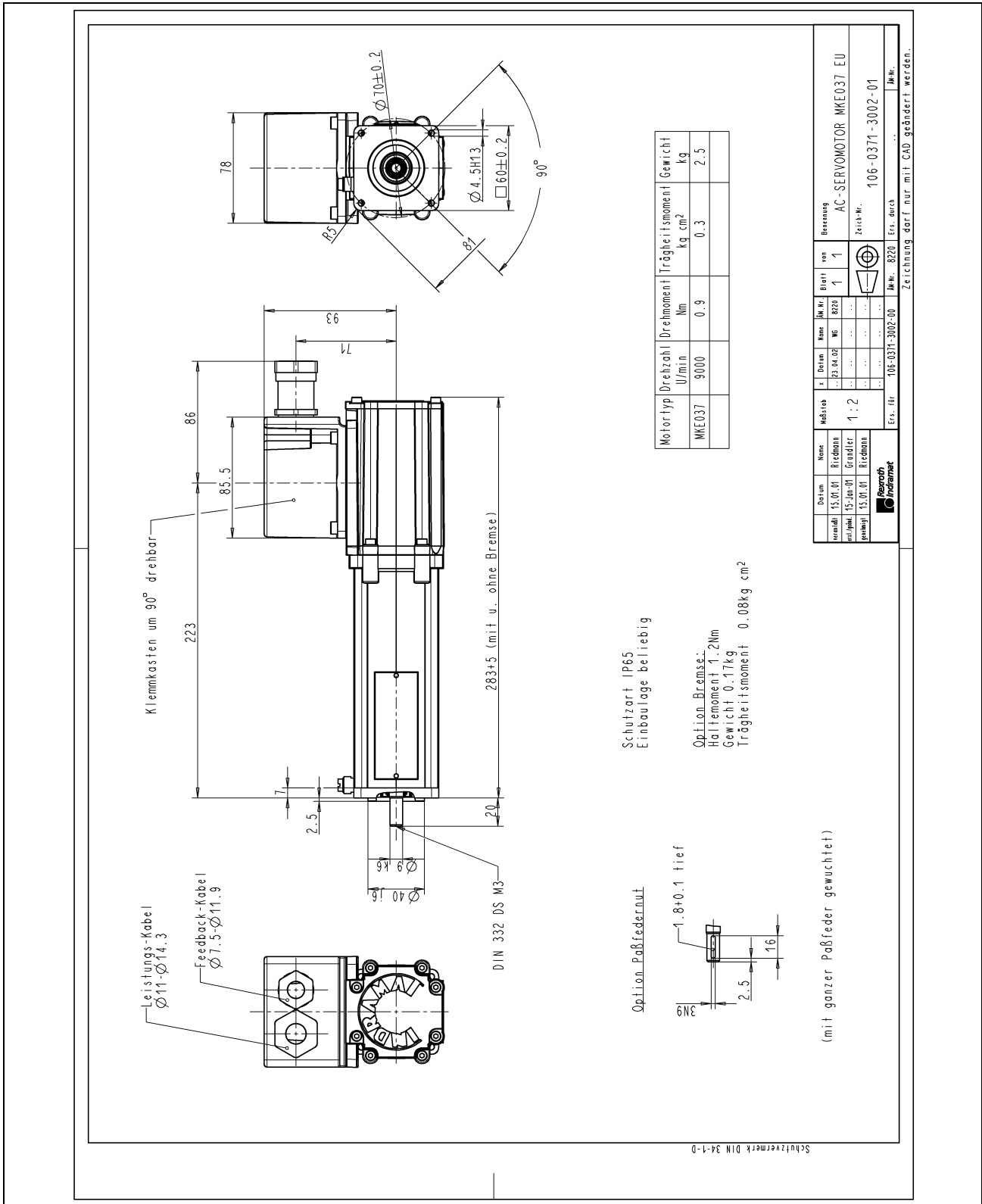

Fig. 5-1: Dimensions MKE037 ATEX

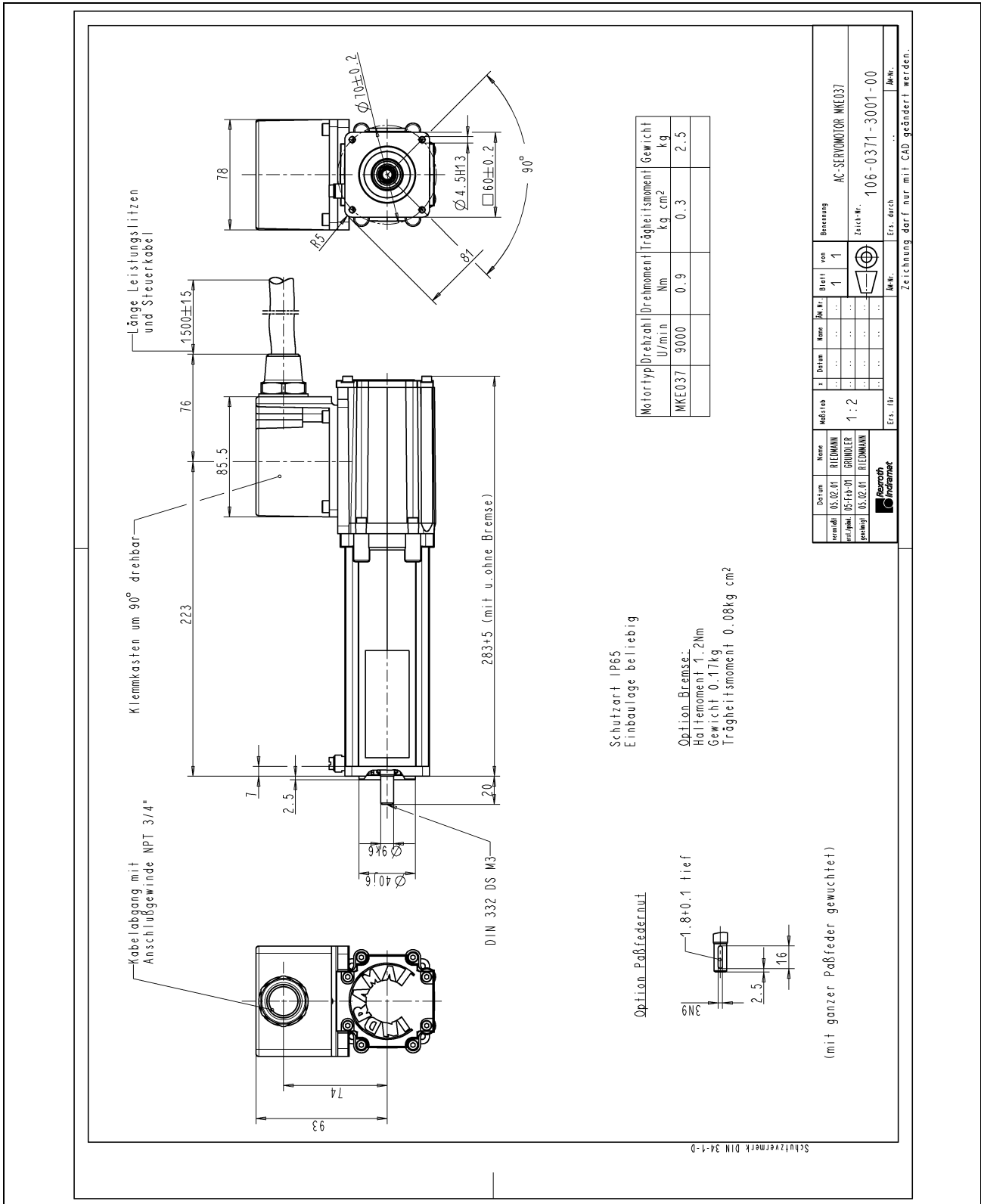

Fig. 5-2: Dimensions MKE037 UL/CSA

Shaft end

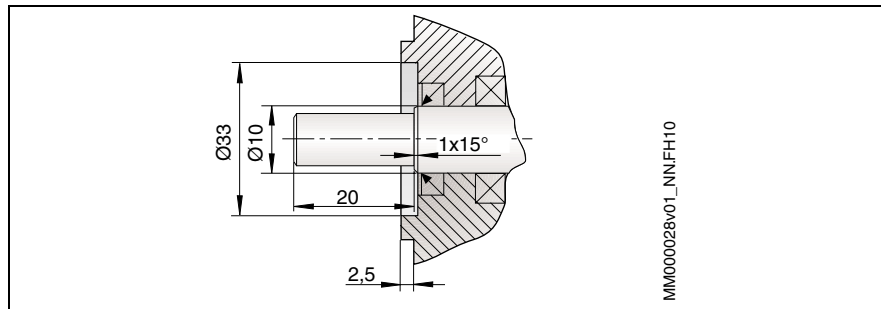

Fig. 5-3: Stub shaft MKE037

- Shaft end cylindrical according to DIN 748, Part 3, ed. 07.75. IEC 60072 (1971).
- DS M3 centering hole according to DIN 332, Part 2, ed. 05.83, max. tightening torque for screw 0.7 Nm.
- Vibration severity grade N according to DIN VDE 0530, Part 14, ed. 02.93.

- Motor design**
- Motor design B5 according to EN 60034-7 / 1993 for all installation positions.

- Flange**
- Flange according to DIN 42948, ed. 11.65.
 - Positional accuracy with regard to true running, axial running and coaxiality to the shaft according to DIN 42955 Tolerance Class R, ed. 12.81

- Output shaft**
- Plain shaft (preferred type)
- or**
- Shaft with keyway according to DIN 6885, Sheet 1, ed. 08.68.

Note: Caution! Balanced with **complete** featherkey!

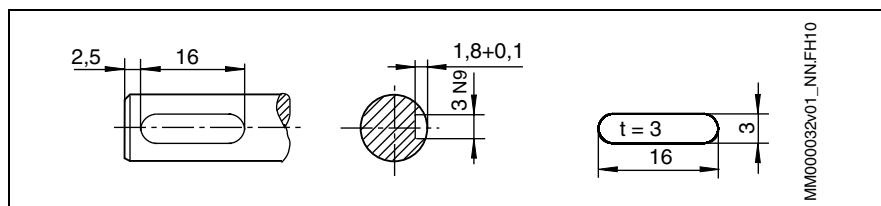

Fig. 5-4: Output shaft with keyway MKE037

Note: Pertinent featherkey: DIN 6885-A 3 x 3 x 16; not included in the scope of delivery of the motor.

- Options** For options refer to the chapter entitled "Type Code – Ordering Name".

5.2 Size 047

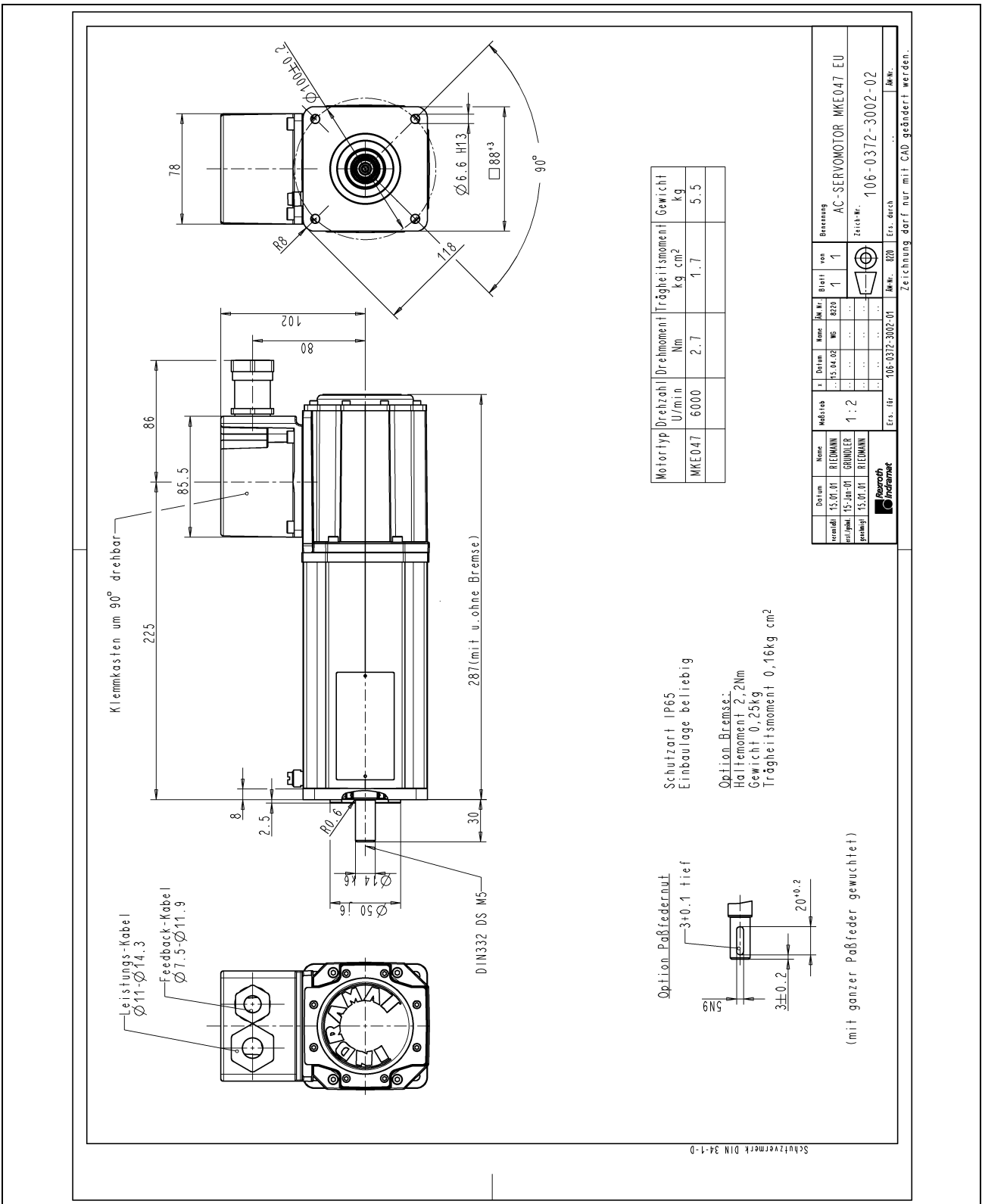

Fig. 5-5: Dimensions MKE047 ATEX

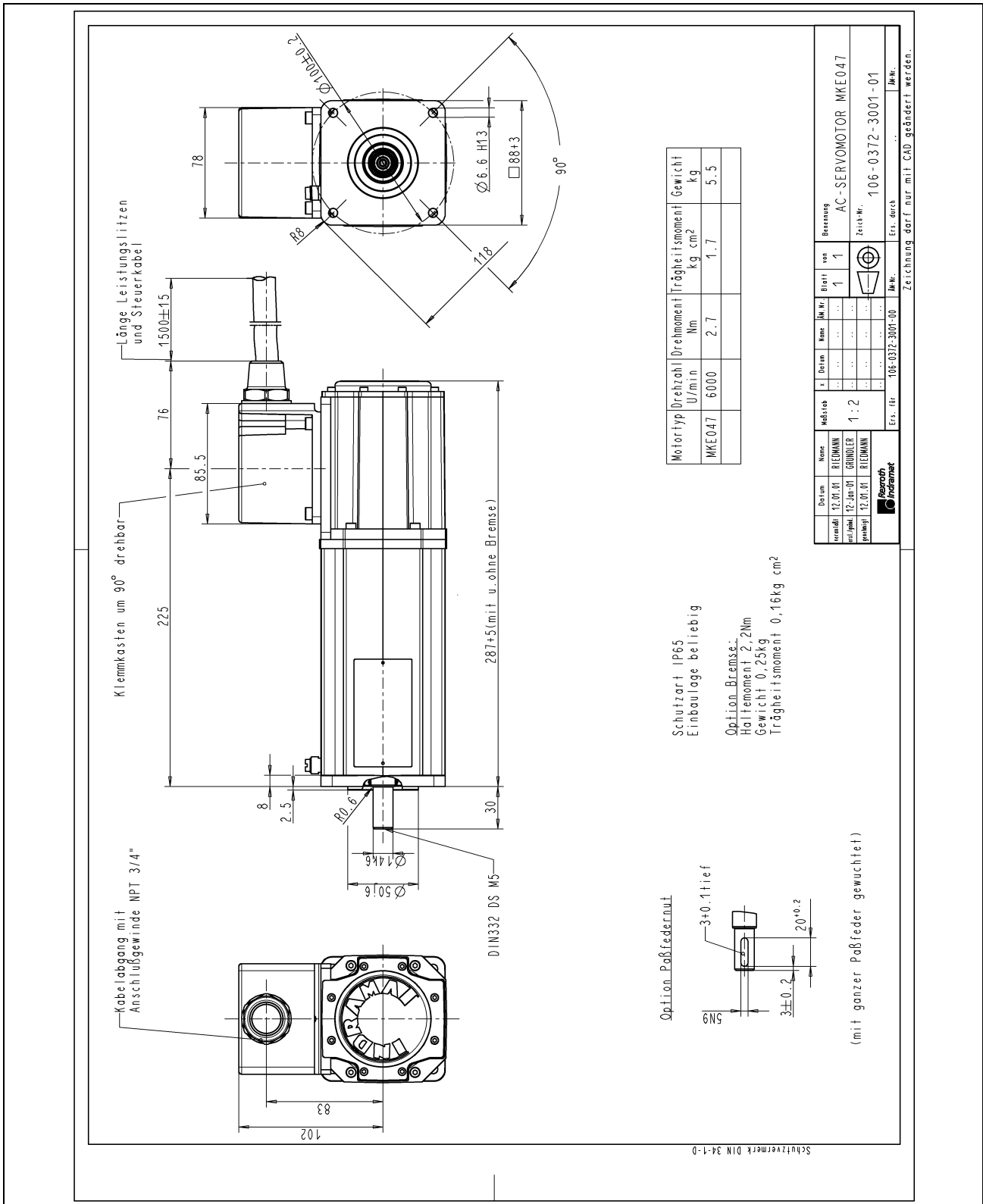

Fig. 5-6: Dimensions MKE047 UL/CSA

Shaft end

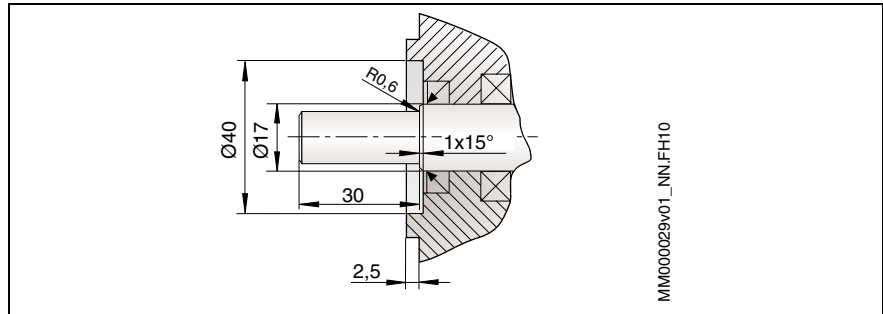

Fig. 5-7: Stub shaft MKE047

- Shaft end cylindrical according to DIN 748, Part 3, ed. 07.75. IEC 60072 (1971).
- DS M5 centering hole according to DIN 332, Part 2, ed. 05.83, max. tightening torque for screw 3.0 Nm.
- Vibration severity grade N according to DIN VDE 0530, Part 14, ed. 02.93.

Motor design

- Motor design B5 according to EN 60034-7 / 1993 for all installation positions.

Flange

- Flange according to DIN 42948, ed. 11.65.
- Positional accuracy with regard to true running, axial running and coaxiality to the shaft according to DIN 42955 Tolerance Class N, ed. 12.81

Output shaft

- Plain shaft (preferred type)
- or
- Shaft with keyway according to DIN 6885, Sheet 1, ed. 08.68.

Note: Caution! Balanced with **complete** featherkey!

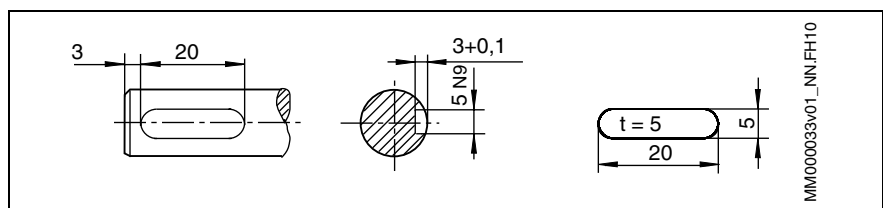

Fig. 5-8: Output shaft with keyway MKE047

Note: Pertinent featherkey: DIN 6885-A 5 x 5 x 20; not included in the scope of delivery of the motor.

Options

For options refer to the chapter entitled "Type Code – Ordering Name".

5.3 Size 098

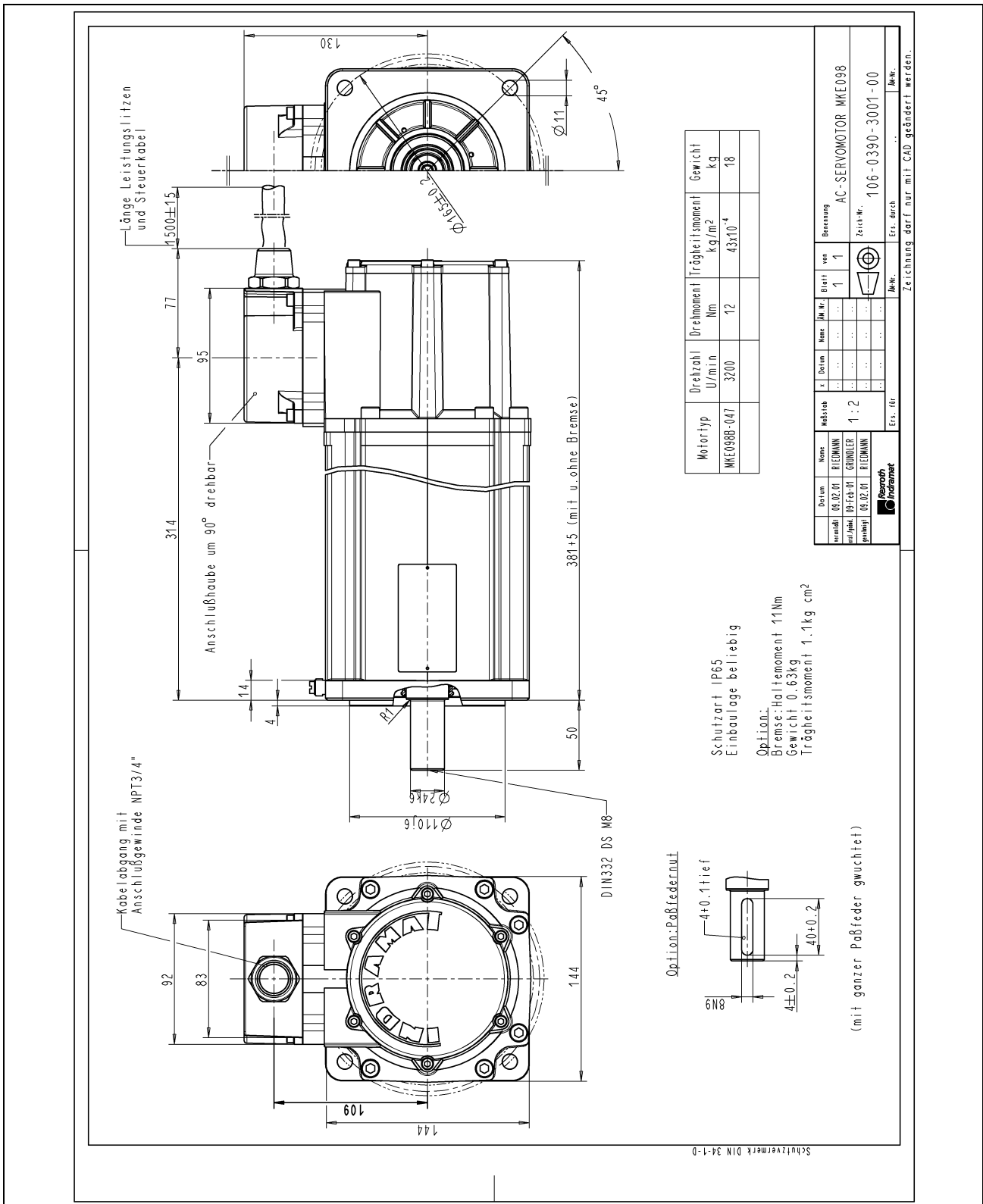

Fig. 5-9: Dimensions MKE098 ATEX

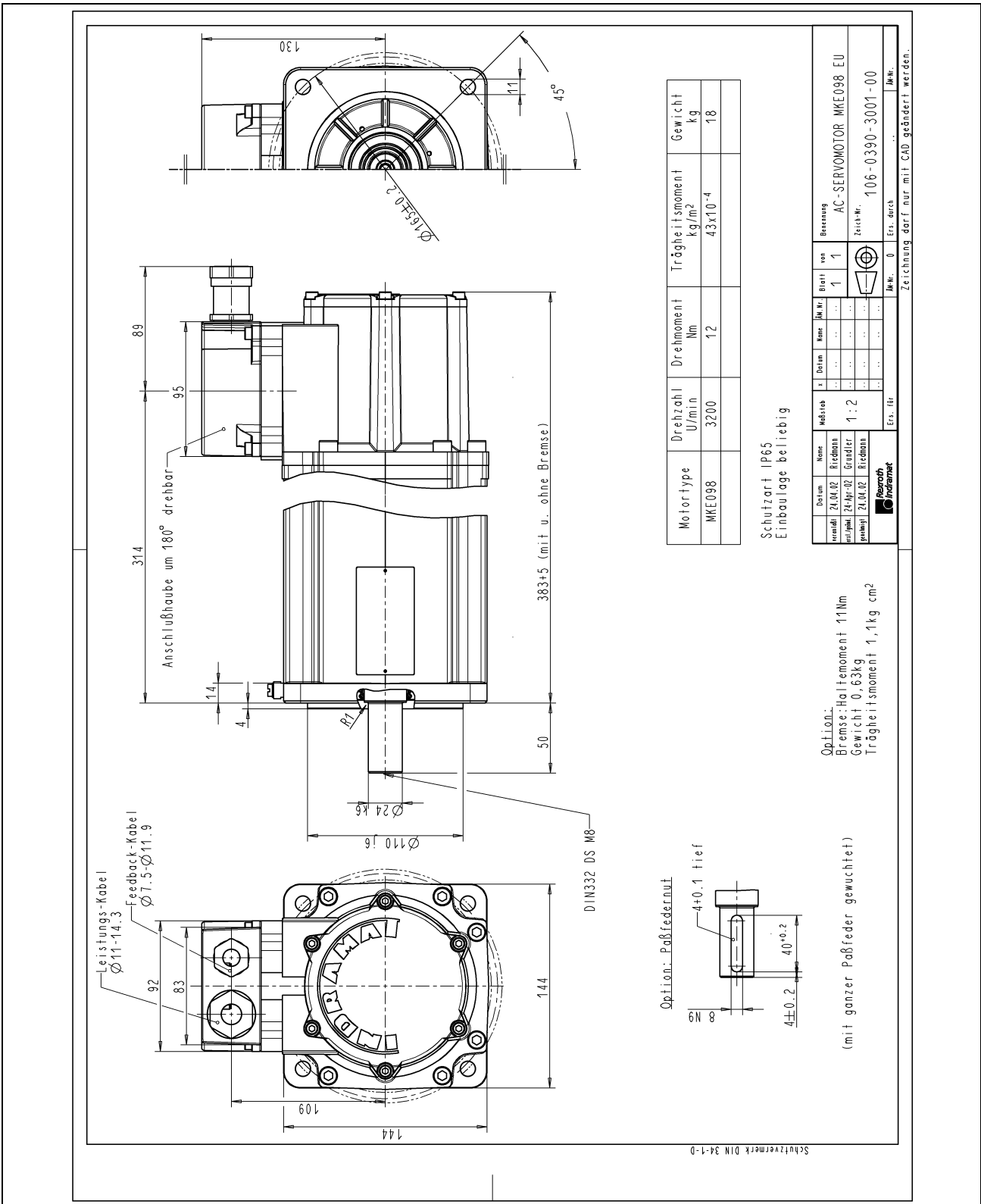

Fig. 5-10: Dimensions MKE098 UL/CSA

Shaft end

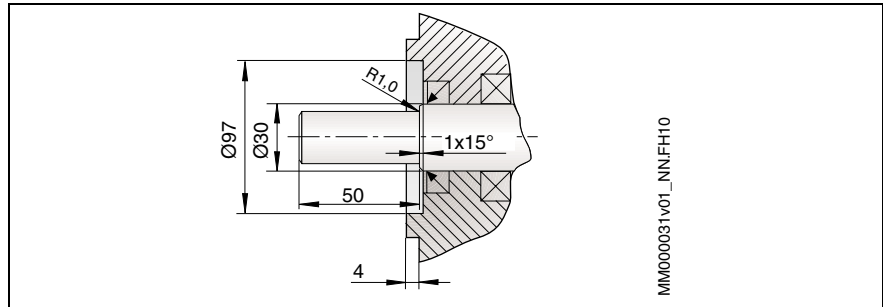

Fig. 5-11: Stub shaft MKE098

- Shaft end cylindrical according to DIN 748, Part 3, ed. 07.75. IEC 60072 (1971).
- DS M8 centering hole according to DIN 332, Part 2, ed. 05.83, max. tightening torque for screw 12.0 Nm.
- Vibration severity grade N according to DIN VDE 0530, Part 14, ed. 02.93.

Motor design

- Motor design B5 according to EN 60034-7 / 1993 for all installation positions.

Flange

- Flange according to DIN 42948, ed. 11.65.
- Positional accuracy with regard to true running, axial running and coaxiality to the shaft according to DIN 42955 Tolerance Class N, ed. 12.81

Output shaft

- Plain shaft (preferred type)
- or
- Shaft with keyway according to DIN 6885, Sheet 1, ed. 08.68.

Note: Caution! Balanced with **complete** featherkey!

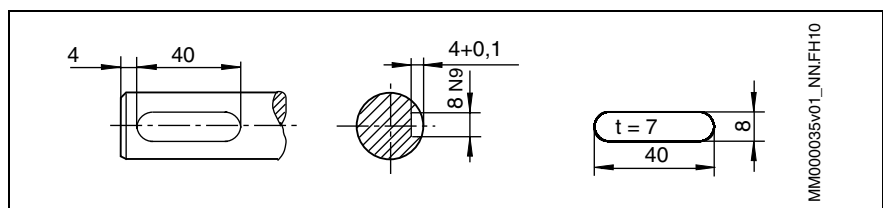

Fig. 5-12: Output shaft with keyway MKE098

Note: Pertinent featherkey: DIN 6885-A 8 x 7 x 40; not included in the scope of delivery of the motor.

Options For options refer to the chapter entitled "Type Code – Ordering Name".

5.4 Size 118

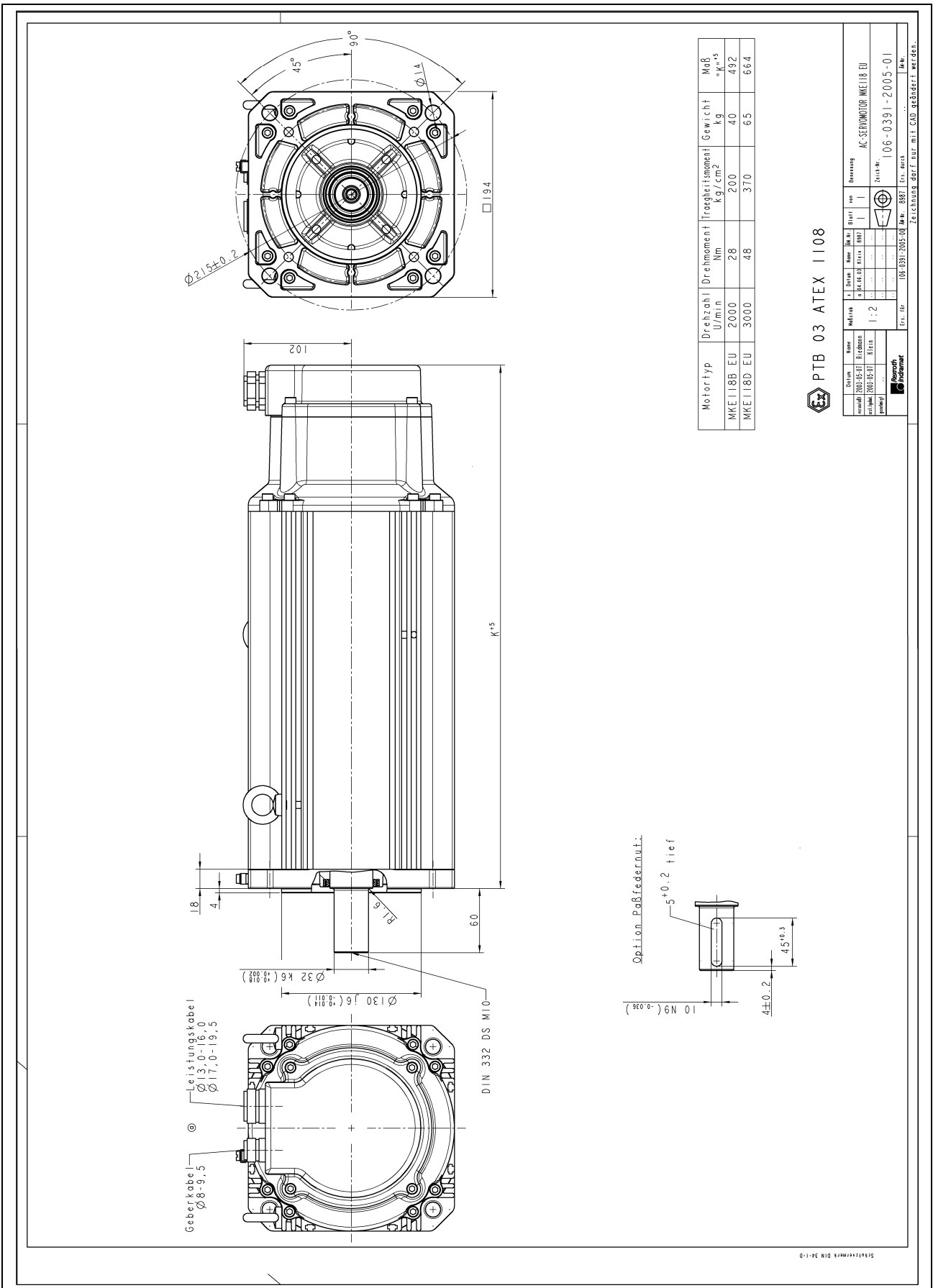

Fig. 5-13: Dimensions MKE118 ATEX

Technical drawing of the MKE118 UL/CSA motor, showing top, side, and detail views with dimensions. The top view shows a hexagonal base with mounting holes and a central shaft with a diameter of $\varnothing 21.5 \pm 0.2$. The side view shows a cylindrical body with a height of 108 mm and a diameter of 42 mm. The bottom view shows the base with mounting feet and a central shaft with a diameter of 10 N9. The detail view shows the bottom view of the motor with a depth of 5+0.2 mm and a diameter of 45±0.3 mm. The motor is labeled with 'DIN 332 DS M10' and '1500±15'.

Motortyp	Drehzahl U/min	Drehmoment Nm	Trägheitsmoment kg·cm ²	Gewicht kg	Maß "K" ⁿ +5
MKE118B	2000	28	2.00	4.0	49.2
MKE118D	3000	48	3.10	6.5	66.4

Option: Paßfedernut:
10 N9 (-0.036)
4±0.2
5+0.2 tief
45±0.3

PROJ. Nr./Zust. Nr.:	PROJ. Zeichen:	Messskala:	Einheit:
30138369	30138354	mm	mm

Größenname	Werte	Größenname	Werte
Wahlzahl	1:2	Max. Drehmoment	48 Nm
Wahlzahl	1:2	Max. Drehmoment	28 Nm

AC-Servomotor MKE118 UL/CSA

0-1-PF-NIG-KAPPAKAPPAKUNGS

MME000043v01_NN.tif

Abb. 5-1: Dimensions MKE118 UL/CSA

Shaft end

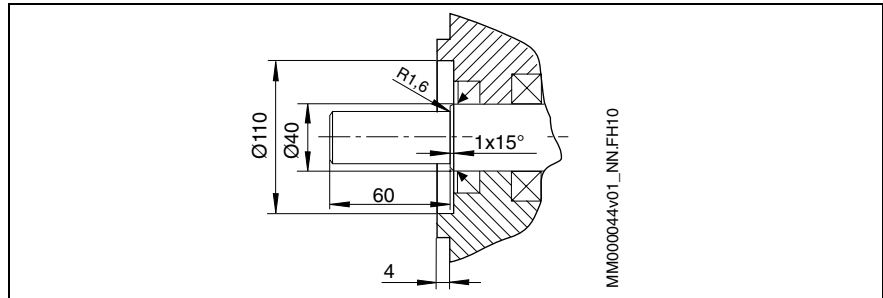

Fig. 5-11: Stub shaft MKE118

- Shaft end cylindrical according to DIN 748, Part 3, ed. 07.75. IEC 60072 (1971).
- DS M10 centering hole according to DIN 332, Part 2, ed. 05.83, max. tightening torque for screw 25 Nm.
- Vibration severity grade N according to DIN VDE 0530, Part 14, ed. 02.93.

Motor design

- Motor design B5 according to EN 60034-7 / 1993 for all installation positions.

Flange

- Flange according to DIN 42948, ed. 11.65.
- Positional accuracy with regard to true running, axial running and coaxiality to the shaft according to DIN 42955 Tolerance Class N, ed. 12.81

Output shaft

- Plain shaft (preferred type)
- or
- Shaft with keyway according to DIN 6885, Sheet 1, ed. 08.68.

Note: Caution! Balanced with **complete** featherkey!

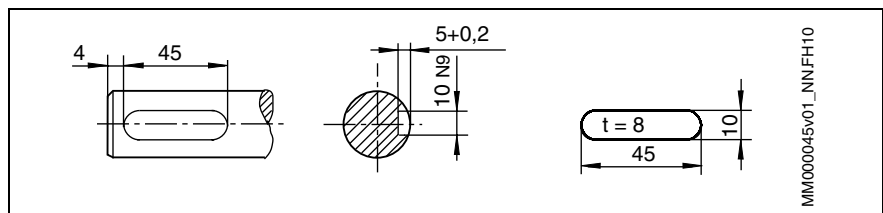

Fig. 5-12: Output shaft with keyway MKE118

Note: Pertinent featherkey: DIN 6885-A 10 x 8 x 45; not included in the scope of delivery of the motor.

Options For options refer to the chapter entitled "Type Code – Ordering Name".

6 Type Code

6.1 Description

Each order of a product by Rexroth must be based on the type code. All available motor versions are uniquely described by their type code. The following figure describes the individual characters of the type code (abbrev. column) and their meaning.

Note:

- The chapter “Application notes” includes detailed explanations for the separate options.
 - Before ordering, please check the availability of the separate options with your Bosch Rexroth Service.
-

Product Group

Abbrev. column 1 2 3

The specific description of Rexroth Indramat series is triple-digit. Servomotors, which are suitable for use in hazardous areas, are characterized by the product group MKE.

Motor Frame Size

Abbrev. column 4 5 6

The motor frame size defines essential mechanical motor dimensions. The following table assigns essential motor dimensions to the motor frame sizes.

Motor Frame Size	Flange size in mm	Centering diameter in mm
037	60	40
047	88	50
098	144	110
118	194	130

Fig. 6-1: Flange size of MKE motors, centering diameter

Motor frame length

Abbrev. column 7

Within the scope of a motor frame size, the motor frame length defines the various continuous torques at standstill.

Motor Frame Size	Continuous torque at standstill	
	Size B	Size D
037	0,9	---
047	2,7	---
098	12,0	---
118	28,0	48,0

Fig. 6-2: Continuous torque at standstill for MKE motors

Winding code

Abbrev. column 9 10 11 In connection with the motor frame size and motor frame length, the winding codes define the electric motor output data for all Rexroth Indramat motors.

The type code specifies all possible winding codes, which are available for a motor frame size / length.

Example

Motor frame size / length	Available winding codes
MKE037B	144

Fig. 6-3: Winding code example

In chapters 7 to 9, the technical data and the speed-torque curves are specified for all motors.

Motor encoder

Abbrev. column 13 MKE motors are equipped with an integrated encoder system (motor feedback). To control the motor speed and/or to position the motor, the drive controller requires information on the current motor position.

To achieve this, the integrated encoder system (motor feedback) makes the appropriate signals available to the drive controller.

The following options are available:

Option	Type	Measurement method	System accuracy	Position input type
G	Digital resolverfeedback	Inductive	±8 angular minutes	Relative
K	Digital servo feedback (HSF with integrated multiturn absolute encoder)	inductive	±8 angular minutes	Absolute (more than 4096 revolutions)
N	Digital servo feedback (HSF)	Optically	±0.5 angular minutes	Relative
P	Digital servo feedback (HSF with integrated multiturn absolute encoder)	Optically	±0.5 angular minutes	Absolute (more than 4096 revolutions)

Fig. 6-4: MKE motor encoder

Output shaft

Abbrev. column 14 To connect the machine elements to be driven to the motor shafts, the following options are available for MKE motors.

Option	Design	Detail
G	Plain shaft	With end-sided centering hole with "DS" thread according to DIN 332, Part 2, Edition 05.83
P	Shaft with keyway ¹⁾	
1) Keyway according to DIN 6885, Sheet 1, ed. 08.68. For details, refer to the motor rating sheet!		

Fig. 6-5: MKE output shafts

Note: MKE motors are balanced with the **complete** featherkey. The pertinent featherkey is not included in the scope of delivery.

Holding brake

Abbrev. column 15 Optional. Required for clamping the servo axis when the machine is in the de-energized state.

Option	Holding Brakes	
0	Without holding brake	
1, 3	With holding brake	Please refer to the motor type codes for the holding torques.

Fig. 6-6: MKE holding brake

The holding brake is operated according to the "electrically releasing" principle. In the de-energized state, a magnetic force acts upon the brake armature disk. This causes the brake to close and to hold the axis.

By applying 24 VDC ($\pm 10\%$), the permanent magnetic field is compensated by the electrically generated magnetic field: the brake opens.

Note: Please also observe the installation and safety instructions on the motor holding brakes in the chapter entitled "Application Instructions".

Output Direction of Power Connector

Abbrev. column 17 The power resp. the encoder connection on the MKE motors has to be made over the terminal box generally. When mounting, the favourite cable outlet direction can be set by twisting of the terminal box.

Supplied Condition MKE motors are available with a terminal box. The cable outlet direction of the UL/CSA motors will be delivered according to the order. At the EU performance of the motors is the output direction B available. However, the output direction can be changed when mounting the motor.

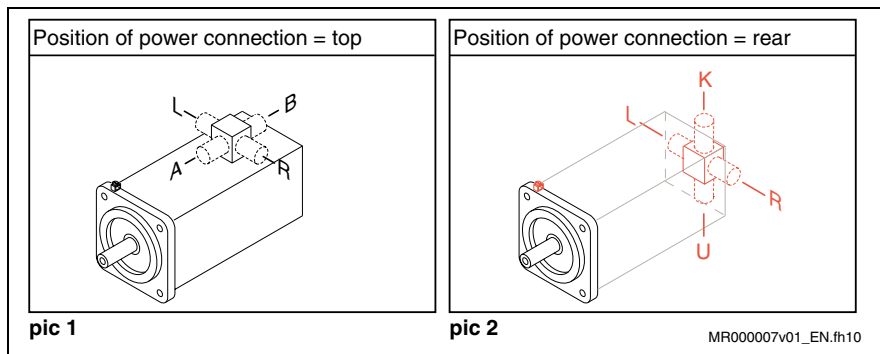

Picture 1: is intended for MKE037, -047, -098

Picture 2: is intended for MKE118

Fig. 6-7: Position of the power connector for motors MKE

Housing type

Abbrev. column 18 Different instructions depend on the place of destination (country). Before ordering, select the housing in accordance to the country of destination of the motors. The following modifications of the housing type can be chosen.

Option	Housing type	Remark
E	According to European standard (EN)	Output direction power connection only for B side
U	According to American Standard (UL)	

Fig. 6-8: MKE housing type

Housing type "U" for North America (USA, Canada)

Housing type "E" for Europe and Asia

Other types

Abbrev. column 19 20 No special type available.

Reference to Standards

The item "reference to standards" indicates standards referred to in the type code (e.g. DIN, EN, ISO, etc.) or also applicable factory standards (INN . . .). The version listed is always that valid at the time of type code issuing.

Remark

Please refer to this item for additionally required information concerning the handling of the type code. This includes, e.g, descriptions on footnotes, notes on availability, or exclusion clauses.

6.4 Type code size 098

Abbrev. Column	1	2	3	4	5	6	7	8	9	0	1	2	3	4	5	6	7	8	9	0	2	1	2	3	4	5	6	7	8	9	0	3	1	2	3	4	5	6	7	8	9	0	4						
Example:	M	K	E	0	9	8	B	-	0	4	7	-	K	P	1	-	R	U	N	N																													

- 1. Product**
 - 1.1 MKE = MKE

- 2. Motor size**
 - 2.1 098 = 098

- 3. Motor length**
 - 3.1 Length = B

- 4. Windings code**
 - 4.1 MKE098B = 047
 - 4.2 MKE098B = 058

- 5. Motor encoder**
 - 5.1 Resolver feedback = G
 - 5.2 Resolver feedback with integrated multiturn absolute encoder = K
 - 5.3 digital servo feedback = N
 - 5.4 digital servo feedback with integrated multiturn absolute encoder = P

- 6. Output shaft**
 - 6.1 plain shaft (with shaft sealing ring) = G
 - 6.2 shaft with key per DIN 6885-1 (with shaft sealing ring) = P

- 7. Holding brake**
 - 7.1 without holding brake = 0
 - 7.2 holding brake 11 Nm = 1

- 8. Output direction of power connection**
 - 8.1 Terminal box to side A = A
 - 8.2 Terminal box to side B = B
 - 8.3 Terminal box to the left = L
 - 8.4 Terminal box to the right = R

- 9. Housing design**
 - 9.1 per european standard (EN) = E
 - 9.2 per american standard (UL) = U

- 10. Other design**
 - 10.1 none = NN

- 11. Standard reference**

Standard	Title	Edition
DIN 6885-1	Drive Type with Fastenings without Taper Action; Parallel Keys, Keyways, Deep Pattern	1968-08
DIN EN 50014	Electrical apparatus for potentially explosive atmospheres - General requirements; Amendment AA; German version EN 50014:1997/prAA:1999	1998-02
DIN EN 50018	Electrical apparatus for potentially explosive atmospheres - Flameproof enclosures "d"; German version EN 50018:1994	1995-03
UL 508C	Power conversion equipment	1996-11
UL 674*ANSI 674	Electric motors and generators for use in division 1 hazardous (classified) locations	1994-04
UL 1446	Systems of insulating materials - General	1997-05

Note:

- ① Looking from front onto driven shaft (see picture 1)
- ② Housing design "E" is only available with output direction of power connection "B"

Fig. 6-11: Type code MKE098

typecodeMKE098_2003-10-06_en.fm10

7 Accessories and Options

7.1 Motor encoder

To control the motor speed and/or to position the motor, the drive controller requires information of the current motor position.

To achieve this, the integrated encoder system (motor feedback) makes the appropriate signals available to the drive controller. The drive controllers are capable of transmitting the positional value thus determined to a superordinate CNC or SPS.

Encoder data memory “motor feedback encoder data memory”

The encoder electronics is equipped with a data memory where the motor type name, the control loop parameters and the motor parameters are filed.

These data are read by the digital intelligent drive controllers by Bosch Rexroth. This ensures

- quick and easy startup,
- adjustment between the motor and the drive controller without the risk of damage to the motor.

Following encoder variants are available for MKE motors:

Option 1)	Encoder type	Measurement method	System precision	Position input type	Position resolution at the motor
G	Digital resolverfeedback	inductive	±8 angular minutes	Relative	MKE037, 047 $3 \times 2^{13} = 24\,576$
K	Digital servo feedback (HSF with integrated multiturn absolute encoder)	inductive	±8 angular minutes	Absolute (more than 4096 revolutions)	MKE098 $4 \times 2^{13} = 32\,768$ Information / environment
N	Digital servo feedback (HSF)	Optically	±0.5 angular minutes	Relative	MKE098, 118 $512 \times 2^{13} = 4.194.304$ information / revolution
P	Digital servo feedback (HSF with integrated multiturn absolute encoder)	Optically	±0.5 angular minutes	Absolute (more than 4096 revolutions)	

1): Option N, P only available for MKE098

Fig. 7-1: MKE motor encoder

Resolverfeedback (RSF) Provided for relative indirect position detection. Replaces separate incremental encoders at the motor.

Note: Characteristics of the resolverfeedback: After a voltage failure or after the first POWER ON, the axis must first always be moved to its home position, before the processing can begin.

⇒ Consider when placing the home position circuit breaker and during the reference, that the resolver during a mechanical motor rotation generates several index signals.

- At MKE037 and MKE047: 3 index signals per rotation
- At MKE098: 4 index signals per rotation

⇒ Avoid too high gear ratio or to slight feed-constant.

Digital servo feedback (RSF with integrated multiturn absolute encoder) Provided for absolute indirect position detection within 4096 motor revolutions. Replaces separate absolute value encoders at the motor.

Note: The absolute axis position at this encoder variety is still exist because of the battery back-up, also after power shut down. The nominally durability of the batterie is about 10 years.

Digital servo feedback (HSF) Provided for relative indirect position detection. Replaces separate incremental encoders at the motor.

Note: After a voltage failure or after the first POWER ON, the axis must first always be moved to its home position.

Digital servo feedback (HSF) with integrated multiturn absolute encoder Provided for absolute indirect position detection within 4096 motor revolutions. Replaces separate absolute value encoders at the motor.

Note: The absolute axis position at this encoder variety is still exist because of the battery back-up, also after power shut down.

7.2 Holding Brakes

Use the brake in **normal operation** only at a standstill and when performing the drive-internal brake check. The holding brake is required for holding the axis when the machine is in a de-energized state.

Please consider the important application notes when using the holding brakes in chapter “9.8 Operation instructions and application notes”.

Note: For technical data and availability of holding brakes see chapters “Technical data” and “Type codes”.

7.3 Gearboxes

Planetary gearbox

Planetary gearboxes of the series GTS and GTP are suitable for assembly on MKE motors.

They are suited for use in S5-operation in gear racks or toothed belts in handling systems with high speed and accelerations (e.g.: loader, robots).

Note: Encoders have no check on Ex-protection. For MKE motors with assembled encoders Bosch Rexroth assumes no liability. The Ex-protection verification certificate refers exclusively to the MKE motors. All further mechanical add-on pieces are not considered and need an additional discharging of the machine manufacturer.

- High operational reliability**
- Low-maintenance operation owing to lifetime lubrication
 - Use under adverse environmental conditions is possible (owing to the completely closed design in IP 65 degree of protection)

- High performance data**
- Low-play gear teeth with minimum reverse play owing to ground gear pairs
 - High torsional strength owing to load distribution to three planetary wheels
 - High efficiency owing to planetary wheel principle
 - High dynamics owing to low masses of inertia
 - Low weight owing to compact design

- Easy attachment to machine**
- Direct overhung mounting of pinions and belt pulleys, owing to the bearing being designed for high permissible radial loads
 - The flange design allows attachment according to design B5 (EN 60034, Part -7, ed. 1993) with hole in the flange.

The output shaft can be mounted in two different ways:

- friction-locked shaft-hub connection by means of a plain shaft, or
- friction-locked shaft-hub connection by means of an output shaft with keyway.

8 Connection System

8.1 Overview

MKE motors can either be delivered in housing construction E (according to European Standard EN) or in housing construction U (according to American Standard UL). The different instructions of the responsible public authority require the subsequent shown connection variants.

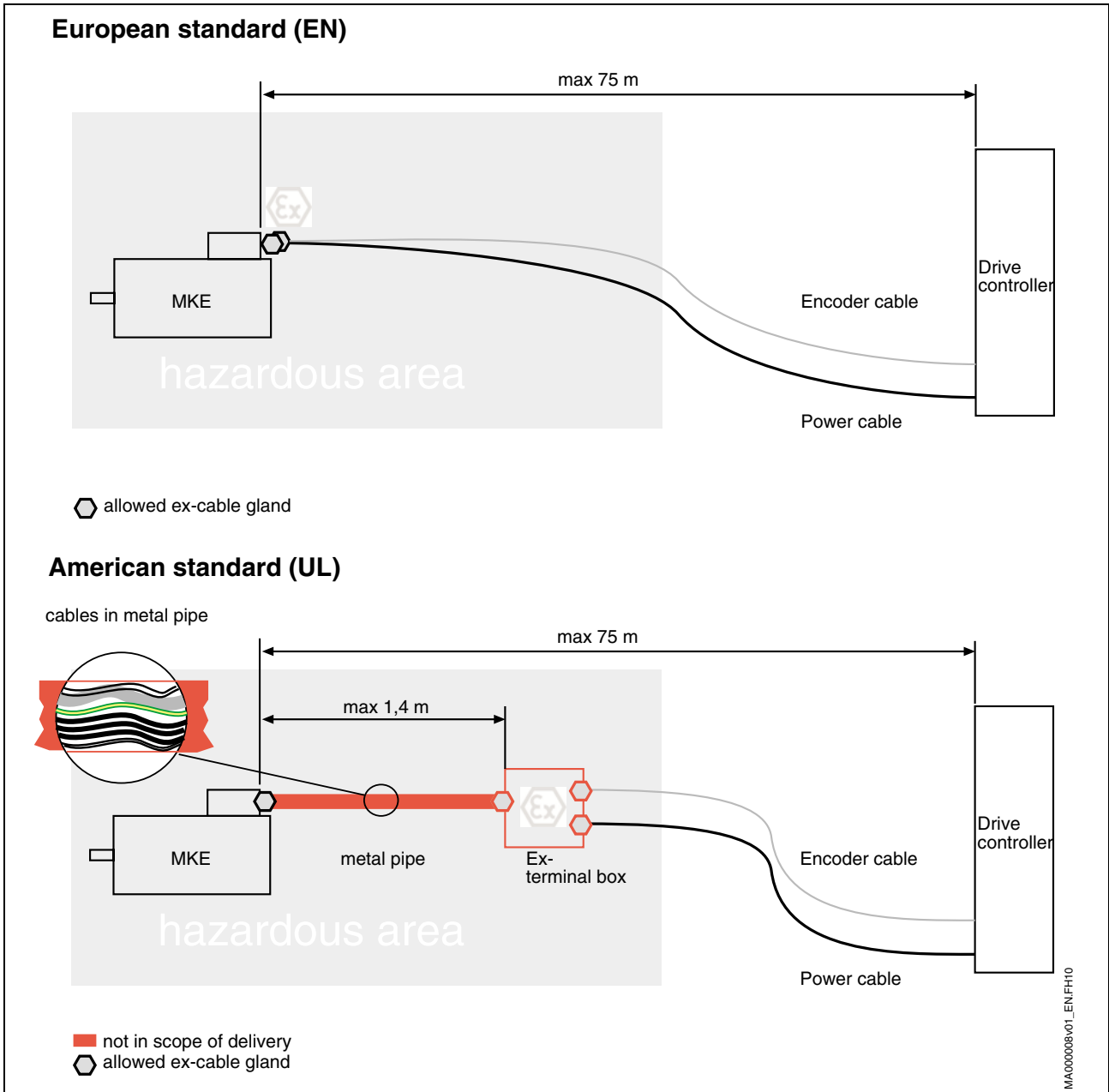

Fig. 8-1: Connection variants MKE motors

Connection temperature control

The analysis of the motor temperature has to be done over the drive-devices of the product families

- ECODRIVE
- DIAX04
- IndraDrive

at Rexroth when MKE motors are used in hazardous areas.

The connection of the PTC-resistors for the motor temperature analysis comes from the particular connection diagram of the drive-devices.

Note: The temperature analysis of the motors **must be done** with drive-devices of Rexroth!

- The PTC-resistor connectors [1] and [2] have to be connected with the temperature control of the drive-device [TM+ , TM-].
-

The MKE motors are according to the temperature class T4 EN 50014: 1992 (European standard). Thus, a maximum surface temperature of the equipment of ≤ 135 °C is allowed. The PTC-resistors mounted in the MKE motors ensure a reliable and safe overtemperature interruption in connection with the plotting system of the drive-devices.

Additional protective conductor

Protective conductor for	Nominal cross section	Cross section
MKE037 MKE047 MKE098 MKE118	2.5 mm ²	2.5 mm ² fine-strand up to 4.0 mm ² single-strand

Fig. 8-2: Additional protective conductor

Connection Cable

Temperature resistance

For using the MKE motors in explosive areas, cables with a temperature resistance of min. 80°C (176°F) have to be used.

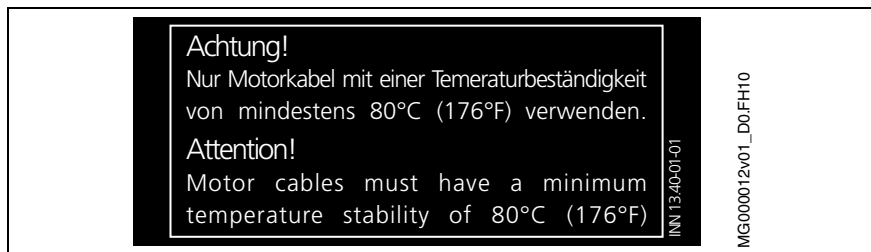

Fig. 8-3: Information sign temperature resistance connection cable

The cables of Rexroth, stated in the selective lists comply with this requirements.

Ready-made connection cables

Ready-made connection cables in various length for motors according to European Standard can be ordered at Bosch Rexroth.

For this selection the following documentation should be used:

DOK-CONNEX-CABLE*STAND-AUxx-EN-P

8.2 Motor connection according to European standard (EN)

The connection of the MKE motors, according to European standard, consists of the following components:

- a power connector, incl. connection for temperature sensor and holding brake,
- Encoder connection
- additionally outside connection for an equipotential bonding conductor (according to EN 50014: 1992)

Power and encoder connection

The power and the encoder cables have to be lead together with the EExd cable duct into the terminal box and have there be connected with the plug-connector and the screw-terminal.

Protection or equipotential bonding conductor

The connection of the ground terminal is to be made over the leaded ground terminal within the power cable into the terminal box of the motor.

An additional connector of a grounded earth conduction or a potential equalization line according to EN 50014: 1992 is specified for the MKE motors. All MKE motors have to be grounded over the additional connection part (ground terminal clamp on the motor flange). Ground terminal cross section see Fig. 8-2.

Overview of Connections

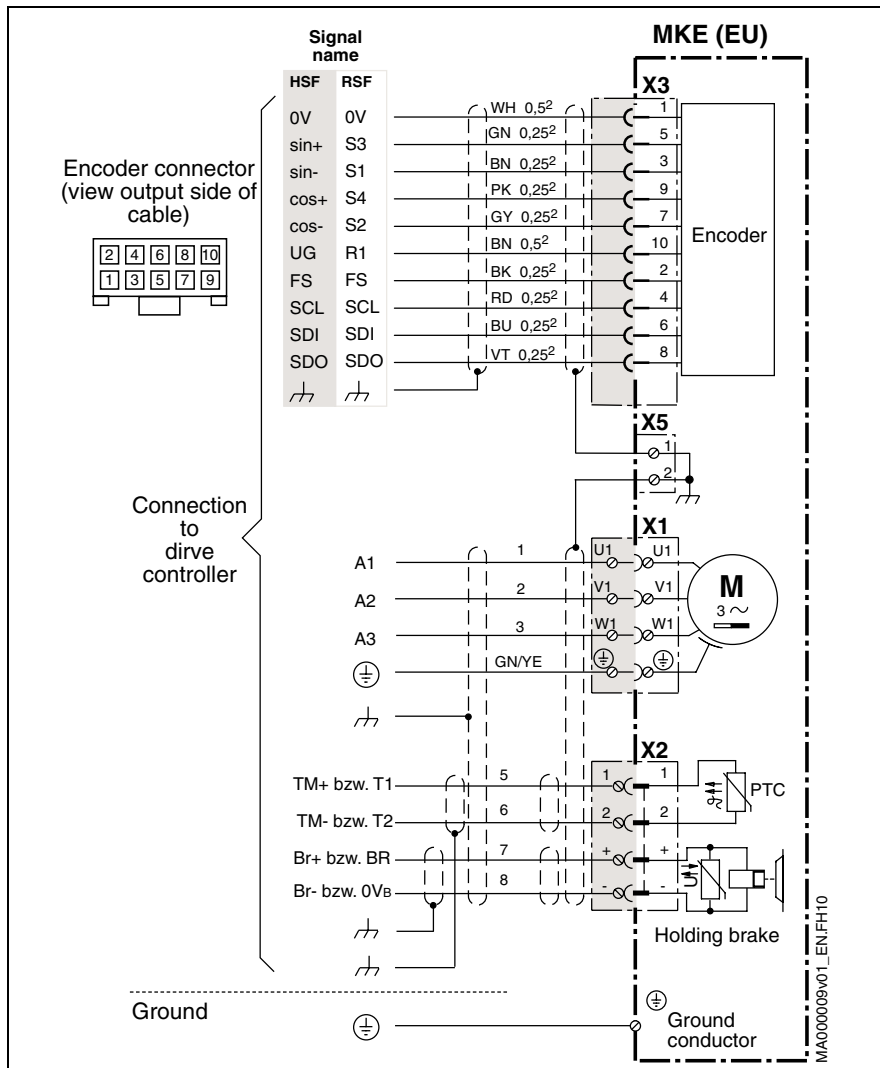

Fig. 8-4: Connection overview MKE according to European standard

8.3 Connection according to American standard (UL)

The connection of the MKE motors, according to American standard, consists of the following components:

- a power connector, incl. connection for temperature sensor and holding brake, single-wire construction
- Encoder connection, standard-cabel construction
- additionally outside connection for an equipotential bonding conductor (according to EN 50014: 1992)

Power and encoder connection

The connecting line of the MKE motors are to be performed through a special cable duct into the motor. The 1.5m long connecting line has to be performed through a 3/4 inch metall pipe into an allowed Ex terminal box (see Fig. 8.1). Standard connecting lines lead from an Ex terminal box to a drive-device.

Protection or equipotential bonding conductor

The connection of the ground terminal is to be made over the leaded ground terminal within the power cable into the terminal box of the motor.

An additional connector of a grounded earth conduction or a potential equalization line according to EN 50014: 1992 is specified for the MKE motors. All MKE motors have to be grounded over the additional connection part (ground terminal clamp on the motor flange). Ground terminal cross section see Fig. 8-2.

Overview of Connections

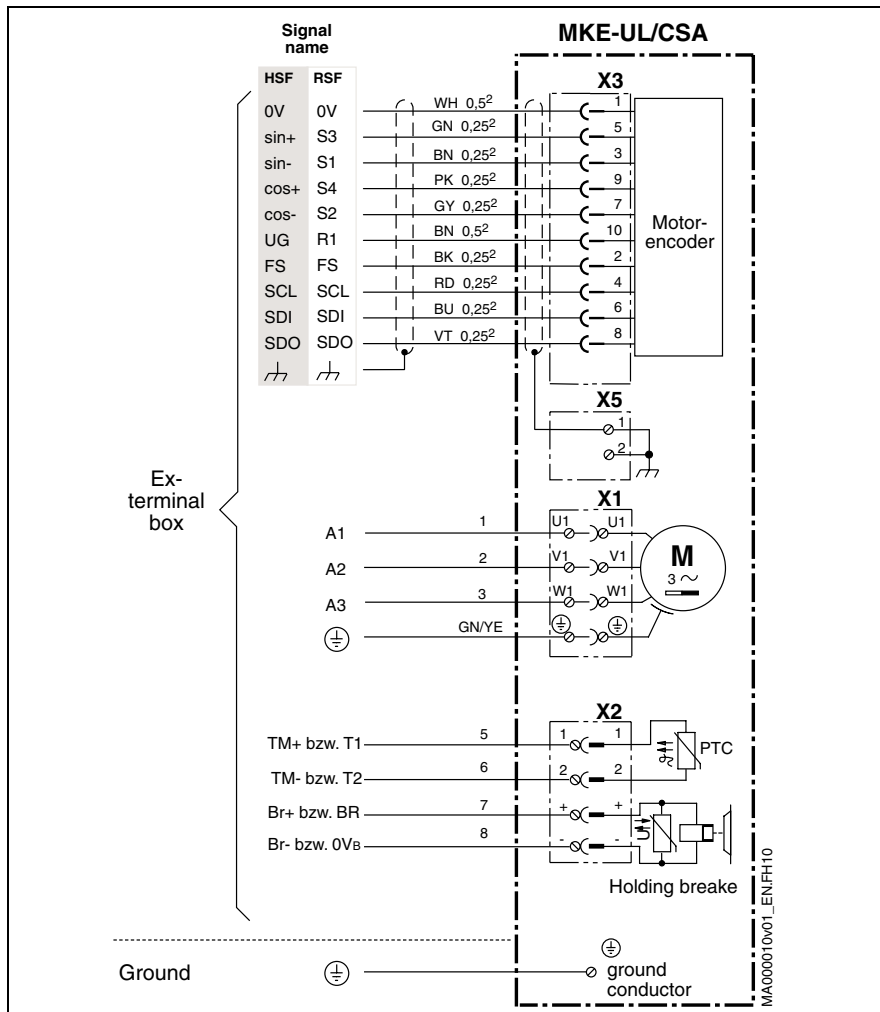

Fig. 8-5: Connection overview according to American standard

8.4 Dimensioning power cable

The specified and calculated cross sectional area of the cables in Bosch Rexroth documentation base on RMS current and the assumption for “rotating motors”. Base for this calculation are the specified stillstand-constant current in the technical data. They are specified as peak values.

The relevant electric currents are in association as follows:

“rotating motor”

$$I_{(Cabel)} = \frac{I_{dN(Motor)}}{\sqrt{2}}$$

$I_{(cable)}$ Relevant electric current to dimensioning for the cable

$I_{dN(Motor)}$ Stillstand-constant current motor (peak values)

Fig. 8-6: RMS – and peak values (“rotating motor”)

In general, the dimensioning concerning the RMS current is sufficient at a “rotating motor”.

“motor at standstill”

$$I_{(Kabel)} = I_{dN(Motor)}$$

$I_{(cable)}$ relevant electric current to dimensioning for the cable

$I_{dN(Motor)}$ Stillstand-constant current motor (peak values)

Fig. 8-7: RMS – and peak values (“motor at stillstand”)

In some cases, applications, working over a longer period, require a continuous torque at standstill when speed = 0 min⁻¹ for the motors (standard value see Fig. 8-8 is recommended to manage the cable-dimensioning as specified peak values in the technical datas (“standstill motor”).

Motor type		Period
MKE	037	10 min
MKE	047, 098, 118	15 min

Fig. 8-8: Working over a longer period

Note: The specified, recommended minimum cross sections is to be checked by the machine/system manufacturer for the machine/system-specific conditions and, if necessary, corrected.

8.5 Recommendation for handling and application, Cable assembly in drag chains

The reachable operating time of cables depends on the mode of installation and environmental factors at the place of action. By the various operating conditions could the following recommendations only be a help to make a long and faultless operation of the cables possible.

General recommendations:

- Do never stress the cables on tension or torsion. Do never pull on the cable when loosen the connectors.
- Do not deviate the cables over sharp edges.
- Do not undergo the minimum bending radius! The same applies for storage on drums or in rings.
- Avoid high temperature variation when storing. For storage outside use covers.
- Cables have to be always unrolled. Do never unroll "over head".
- Do never use damaged cables.

Cables in drag chains

To mount the cables in drag chains in the right way, some basic rules have to be taken into account. Inserting the cables into the drag chains is to be done with utmost care.

- Do only use cables, which are suited for the use in drag chains.
- The minimum bending radius of the drag chains is determined via the cable with the biggest outer diameter.
- Lay out or hang out the cables before mounting so that the twisting regresses. An axial twisting of the cables should be avoided in every case.
- Lay the cables into the drag chains tension-free and twisting-free.
- Lay only laid out or hanged out cables into the drag chains and then mount the chain into the machine.
- Cables should never cross within the chain and also never overlap.
- The cables have to be movable in the area of the bending radius as well as in the width and height. The total diameter of the drag chain should be filled with 85-90% at the maximum.

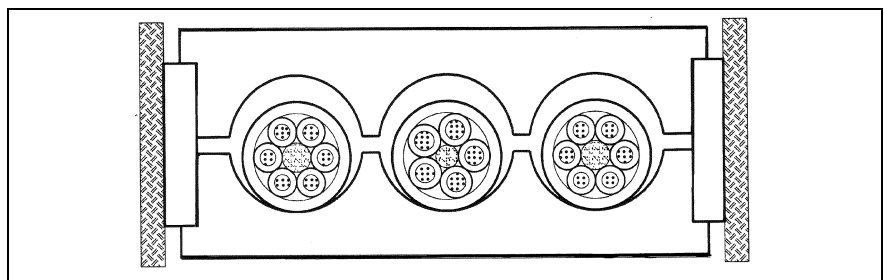

Fig. 1-1: Filling degree of drag chains

- It is not allowed to fasten or to bind the cables together within the chain.

When equipping the drag chain is must be taken into account that the height must be equally allocated symmetrically. This means, heavy cables have to be laid exoteric and the lightweight cables introversive.

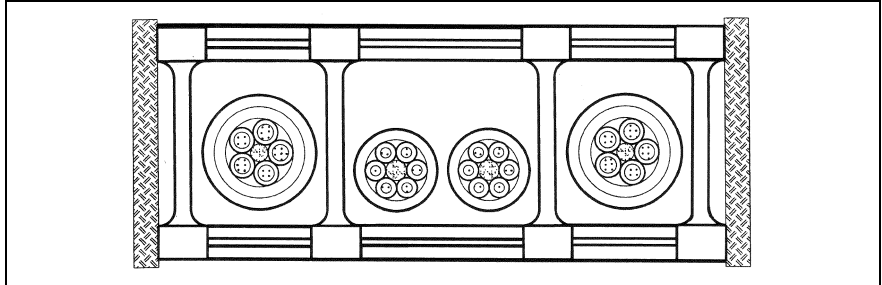

Fig. 1-2: Symmetrical allocation within drag chains

- When allocating the drag chains with cables of different diameters ($> \pm 20\%$) use chains with divided rooms or racks. At multi-layer allocation should bars be mounted between the several layers.

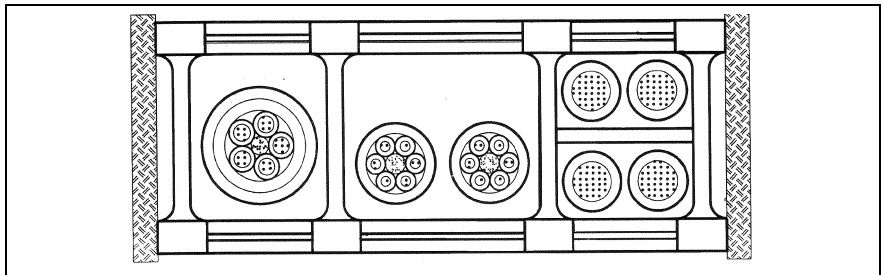

Fig. 1-3: Multi-layer allocation of drag chains

- Before fastening the cables within the drag chains, move them 10 to 20 times minimum. This relaxes the cables and brings them in a neutral position. After about 24 hours operation of the machine should be made a length adjustment.
- Fasten both ends of the cables. Minimum distance is 30x cable diameter measured from the endpoint of the bending motion. The fastening of the cables should be made extensively over the outer jacket. The inner cable-wires (soul) should be negligible squeezed. A strong squeeze shortens the operating time of the cables.

9 Notes Regarding Application

9.1 Hazardous areas

Designation and definition

Apparatus designation according to ATEX

Principle of protection			
Degree of protection	Designation	Use of apparatus in zone	Standard
Pressure-resistant casing	EEx d	1 oder 2	EN 50014 IEC 60079-0 VDE0171 Part
Degree of protection "n"	EEx n	2	EN 50021 IEC 60079-15 VDE 0170/ 0171 Part 16

Conditions in hazardous areas				
Flammable materials	Temporary manner of flammable material within hazardous areas	Classification into hazardous areas	Necessary designation of the applicable apparatus	
			Group	Category
Gases, steams	are always, long-term or frequently existing	Zone 0	II	1G
	occur sometimes	Zone 1	II	2G or 1G
	do probably not occur, but if so, then seldom or temporary	Zone 2	II	3G or 2G or 1G
Dusts	are always, long-term or frequently existing	Zone 20	II	1D
	occur sometimes	Zone 21	II	2D or 1D
	do probably not occur, but if so, then seldom or temporary	Zone 22	II	3D or 2D or 1D

Explosion group	Gases and steams (spreading)				
	Gases and steams				
IIA	Ammonia Methane Ethane Propane	Ethyl alcohol Cyclohexane n-Butane	Benzine generally Nozzle fuel n-Hexane	Acetaldehyde	
IIB	Tow n gas Acrylonitrile	Ethylene Ethylen oxid	Ethylen glycol Hydrosulfide	Ethyl ether	
IIC	Hydrogen	Ethine (Acetylene)			
Temperature classes: Ignition of gases and steams acc. to ignition temperature					
T1 > 450 °C		T2 > 300 up to > 450°C	T2 > 200 up to > 300°C	T4 > 135 up to > 200°C	
Alternative designation e.g. T155 (max. surface temperature 155°C)					

CE 0102  II 2GD EEx d IIB T4 NB 99 ATEX 1234 U

Benannte Stellen (Notified Bodies)	Identification number
PTB	0102

Official authority

Conditions	Designation
Apparatus applicable without restriction	-
Notice special conditions on use	X
Ex- part with part confirmation, not applicable sole; CE- conformity is certified with mounting into a complete apparatus	U

Use of apparatus

Fig. 9-1: Item designation according to ATEX

Equipment Group II Category 1



Equipment designed to be capable of functioning in conformity with the operational parameters established by the manufacturer and ensuring a very high level of protection. Equipment in this category is intended for use in areas in which explosive atmospheres caused by mixtures of air and gases, vapours or mists or by air/dust mixtures are present continuously, for long periods or frequently. Equipment in this category must ensure the requisite level of protection, even in the event of rare incidents relating to equipment, and is characterized by means of protection such that:

- either, in the event of failure of one means of protection, at least an independent second means provides the requisite level of protection; or
- the requisite level of protection is assured in the event of two faults occurring independently of each other.

Note: Motors of equipment group II, category 1 for the use in hazardous areas Bosch Rexroth does not offer.

Equipment Group II Category 2



Equipment designed to be capable of functioning in conformity with the operational parameters established by the manufacturer and ensuring a high level of protection. Equipment in this category is intended for use in areas in which an explosive atmosphere of dust/air mixture can occur **occasionally**. The means of protection relating to equipment in this category ensure the requisite level of protection, even in the event of frequently occurring disturbances or equipment faults which normally have to be taken into account.

Note: The MKE-motors of Rexroth are equipment according to equipment group II, category 2 for use in hazardous areas.

Equipment Group II Category 3



Equipment designed to be capable of functioning in conformity with the operational parameters established by the manufacturer and ensuring a high level of protection. Equipment in this category is intended for use in areas in which explosive atmospheres caused by dust/air mixtures are unlikely to occur or, if they do occur, are likely to do so **only infrequently and for a short period only**. Equipment in this category ensures the requisite level of protection during normal operation.

Note: The MKD-motors type “S” of Rexroth are equipment according to equipment group II, category 3 for use in hazardous areas.

The following designations are used in the European Standard EN 50014: 1992. 1992 verwendet.

Electrical apparatus	All items as a whole or in part for the utilization of electrical energy. These include, among others, items for the generation, transmission, distribution, storage, measurement, regulation, conversion, and consumption of electrical energy for telecommunications.
Hazardous area	An area which could become explosive (the danger is a potential one).
Explosive gas atmosphere	A mixture with air, under atmospheric conditions, of flammable substances in the form of gas, vapour or mist, in which after ignition, combustion spreads throughout the unconsumed mixture.
Explosive test mixture	A specified explosive mixture used for the testing of electrical apparatus for potentially explosive areas.
Operating Temperature	The temperature reached when the apparatus is operating at its rating.
Maximum operating temperature	The highest value of the operating temperature. NOTE: Each apparatus may reach different operating temperatures in different parts.
Maximum surface temperature	The highest temperature which is attained in service under the most adverse conditions (but within the recognized tolerances) by any part or surface of an electrical apparatus, which would be able to produce an ignition of the surrounding explosive atmosphere.
Degree of protection	The specific measures applied to electrical apparatus to avoid ignition of a surrounding explosive atmosphere.
Type of protection of the housing (IP)	A numerical classification preceded by the symbol "IP applied to the housing of electrical apparatus to provide for: <ul style="list-style-type: none"> • protection of persons against contact with or approach to live parts and against contact with moving parts (other than smooth rotating shafts and the like) inside the housing, • protection of the electrical apparatus against ingress of solid foreign objects; and, where indicated by the classification, • protection of the electrical apparatus against harmful ingress of water. NOTE: The housing that provides the degree of protection IP is not necessarily identical to the apparatus housing for the types of protection.
Rated value	A quantity value assigned, generally by the manufacturer, for a specified operating condition of a component, device or apparatus.
Rating	The set of rated values and operating conditions.
Cable entry	A device permitting the introduction of one or more electric and/or fibre optic cables into an electrical apparatus so as to maintain the relevant type of protection.
Ex cable entry	A cable entry tested separately from the apparatus housing but certified as an apparatus and which can be fitted to the apparatus housing during installation without further certification.
Conduit entry	A means of introducing a conduit into an electrical apparatus so as to maintain the relevant type of protection.
Compression element	An element of a cable entry acting on the sealing ring to enable the latter to fulfil its function.
Strain relief device	An element of a cable entry for preventing tension or torsion in the cable from being transmitted to the connections.
Sealing ring	A ring used in a cable or conduit entry to ensure the sealing between the entry and the cable or conduit.
Terminal compartment	A separate compartment or part of a main enclosure, communicating or not with the main enclosure, and containing connection facilities.

Connection facilities	Clamps, screws or other parts, used for the electrical connection of conductors of external circuits.
Execution	An insulation device carrying one or more conductors through an internal or external wall of a housing.
Ex component	A part of electrical apparatus or a module (other than an Ex cable entry), marked with the symbol "U", which is not intended to be used alone and requires additional certification when incorporated into electrical apparatus or systems or use in potentially explosive atmospheres.

Zones

Hazardous areas are classified, in view of the probability to occur in explosive atmosphere, into the following zones.

Note: The following information is based on EN 60079-14: 1997 and the BGBl: 1996 Part 1. For comprehensive information will be referred to these scripts.

Zone 0 Zone 0 includes areas in which an explosive atmosphere, which contains a mixture of air and gas, dust and mist, is available continuously, long-term or frequently.

Electrical apparatus are only allowed for zone 0, if they comply with the specifications according to EN 50020: 1994 (self-security "i"). 1994 (Eigensicherheit „i“) entsprechen.

Zone 1 Zone 1 contains areas in which is to be reckoned occasionally with an explosive atmosphere of gas, dust or mist.

Electrical apparatus are allowed to be used in zone 1, if they are constructed for zone 0 or for one of the degrees of protection described in Fig. 9-2.

Zone 2 Zone 2 contains areas in which it is not to be reckoned with an explosive atmosphere occurred by gas, dust or mist. But if it occurs then in all likelihood rarely or during a short period of time.

Electrical apparatus are allowed to be used in zone 2, if they:

- are constructed according to the claims for zone 0 or 1.
- are especially constructed for zone 2.
- correspond to the claims of an admitted standard for industrial electrical apparatus and have in undisturbed operation no ignitable hot surface.

Degree of protection, groups and temperature classes

The electrical apparatus for hazardous areas are classified into:

Degree of protection The electrical apparatus are constructed according to the degree of protection. The claims are stipulated in special standards.

Degree of protection	Description	Standard
Oil immersion	o	EN50015: 1998
Pressurization	p	EN50016:1995
Powder filling	q	EN50017: 1998
Flameproof enclosure	d	EN50018: 1994
Increased safety	e	EN50019: 1994
Intrinsic safety category a	ia	EN50020: 1994
Intrinsic safety category b	ib	EN50020: 1994
Encapsulation	m	EN50028: 1987

Fig. 9-2: Degree of protection

Electrical apparatus of this degree of protection become certified by a type check from a neutral body.

- Groups**
- **Group I:** Electrical apparatus for mines susceptible to fire damp.
 - **Group II:** Electrical apparatus for paces with a potentially explosive atmosphere, other than mines susceptible to fire damp.

The electrical apparatus of Group II are classified according to the character of explosive atmosphere, for which they are intended for.

For the degree of protection pressure resistant casing "d" and intrinsic safety category "i" all electrical apparatus of Group II are classified in IIA, IIB and IIC (see appendix A according to EN 50014:1992).

For all degrees of protection, the apparatus of Group II have to be labeled with subject to their maximum surface temperature as described in Fig. 9-3.

Temperature classes The maximum surface temperature for electrical apparatus of Group I has to be indicated in the testing documents.

Electrical apparatus of Group II are classified and labeled and have to be either:

- classified preferably in a temperature class in compliance with Fig. 9-3.
- or labeled with the particular maximum surface temperature;
- or, if applicable, labeled with the specific gas for which the apparatus is intended for.

Temperature class	Maximum surface temperature °C
T1	450
T2	300
T3	200
T4	135
T5	100
T6	85

Fig. 9-3: Classification of the maximum surface temperature in classes for electrical apparatus of Group II

Application conditions for MKE motors

Connection condition The motors are only allowed to operate with the Rexroth Drives DIAX04, ECODRIVE, DURADRIVE and INDRADRIVE. Controllers of other manufacturers are not permitted.

The plug-in terminals in the terminal box have to be bolt together securely.

Do not disconnect or connect connectors in explosive areas!

Grounding RPM-regulated drive-systems include unavoidable heat losses over the earth. For this reason the motors have to be grounded over the motor cable and over a separate ground wire with min. as specified in the connecting diagram. The fixed location of the ground terminals has to be checked before put into service.

If connection of the ground wire in the motor cable and the second separate ground wire are not connected on the motor housing or by corrosion and other failures are interrupted during the life-time, the leakage current is floating as leakage current over the conductive housing parts. This has to be prevented with the above-mentioned measures. (ATEX-directive 94/9/EG, appendix II, Cap.1.2.3 and Cap.1.3.3, 1.4)

Danger of corrosion Corrosion by aggressive substances (like specified coolants, lubricants, cutting oil or salt mist) on the motor housing must be prevented.

Emergency cutout Stored energy in the intermediate circuit has to be degraded or isolated as soon as possible via pressing the emergency stop, that in the case of failure the risk of an effect into the danger zone is reduced. (ATEX-directive 94/9/EG, appendix II, Cap. 1.6.2)

The user has the following possibilities:

- Energy isolation is guaranteed from the exit of the drive device, if at emergency stop, in addition to the power loss of the drive device is locked electronically. This results from line contactor-shutdown with subsequent failure reaction of the drive device because of power failure (cp. F281). Adjusting the required drive-end failure reaction must be made by the user at the drive device via the drive parameters (cp. P-0-0119) according to the functional description.
- To have the encoder feeder cable also de-energized, shutdown the control voltage of the drive device.

Are the control voltage and the power of the drive device shutdown, the exit on the motor side has electronically locked itself over the output stage and eventually stored energies in the intermediate direct current link are therewith isolated on the motor side and on the output side.

- The intermediate direct current link short-circuit can be used – if possible – to reduce the energies within the intermediate direct current link of the drive device after shutdown of supply voltage fast.

Independent from these possibilities, the user has to check – as stipulated in the safety notes - with a suited measuring instrument, in general, before working on the machine, if the machine or parts of it, are under load (e.g. caused by rest energy of condensers in filters and drive devices etc.). Wait for their discharging time.

Other Environmental Influences In view of danger via outside influences note the following:

- Operation only inside the specified environmental conditions,
- Do not exceed the maximum vibration and impact load.
- Corrosion by humidity, aggressive substances and contamination on the connection of the ground wire has to be excluded.

Internal motor brake (if existing)

Use the brake inside the motor in **normal operation** only in standstill and for performing the drive-internal brake check. Hereby only poor temperatures of $T < 100\text{ °C}$ are coming up and there is no spark, as no critical grinding occurs.

- Drive of the brake** The brake's control mechanism must ensure this function in normal operation. Under the worst installation condition of the power supply of the brake and under the worst load condition of the supplier with a voltage of $24\text{ V}_{\text{DC}} \pm 10\%$ must be supplied to the motor. Does a voltage divergence occur via a failure during operation, this failure has to be identified and corrected immediately. Identification of the failure can be made, e.g. via an inviligator for undervoltage.
- Malfunction** Only in malfunctions, which can occur through failure within the equipment, it is allowed to press the brake during an engine speed of the motor to avoid, for example, dangerous sinking of the axis. Hereby sparks and increased temperatures in the brake can occur within the motor. After coming-up of this failure, it must be removed by the user.
- Functional test** Before commissioning and in operation in periodic intervals (e.g. every 8 hours) the brake is to be tested on its functions with an appropriate braking test. By applying a defined amount of motor torque, the brake is tested for slippage. Some drive devices have the possibility to carry out an integrated braking test via the command brake control. Further information can be found in the respective firmware operation manual for the drive device.

Type test of the motors according to European standard (EN)

MKE motors are produced according to the European standards

- EN50014: 1992 and
- EN50018: 2000

and are certificated by the Physikalisch Technischen Bundesanstalt PTB.

Motor type	Licence No.	Degree of protection / protection concepts or standards
MKE037/047/098	PTB 03 ATEX 1107 X	pressure-resistant casing d/ acc. To EN 50014 and EN 50018
MKE118	PTB 03 ATEX 1108 X	

Fig. 9-4: Type tests MKE motors.

Certificate of conformity

Declarations of certificate of conformity the structure of and the compliance with the applicable EN standards and EC guidelines are available for all MKE motors. If necessary, these certificate of conformity can be requested from the pertinent sales office.

Note: We recommend to use MKE motors in connection with drive devices of Rexroth Indramat in hazardous areas.

When mounting the drive-devices in hazardous areas, the following components must fulfill the Ex-protection requirements.

motor with attached parts

Into the hazardous area leading current circuits

Hazardous area

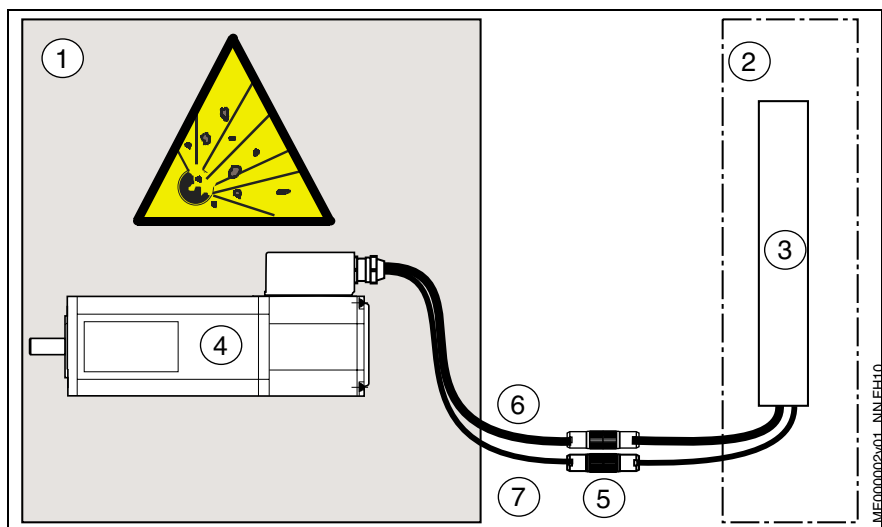

- (1): Hazardous area with explosion protected apparatus
- (2): control cabinet
- (3): drive device
- (4): MKE motor
- (5): Connections
- (6): Motor power cables
- (7): Encoder cable

Fig. 9-5: explosion-endangered area

Use in zone 1 and 2 It is allowed to use MKE motors of Rexroth Indramat in hazardous areas of zone 1 and 2.

The relating drive devices and connections of the connection cables (power and feedback connection) must lay outside of the hazardous area.



DANGER

Danger of explosion, danger to life, heavy injury and property damage

- ⇒ Do not set up drive devices and connectors in hazardous areas.
 - ⇒ Make sure that connectors could not reach into the hazardous areas.
 - ⇒ Do not disconnect the connections under load!
 - ⇒ Make sure that no ignition sparks could occur within the hazardous area.
-

Type test of the motors according to American standard (UL)

MKE motor are produced according to the American standards

- UL 508C/1996-11,
- UL 674/1994-04 and
- UL 1446/1997-05

and checked by the UL authority Underwriters Laboratories Inc.®.

Motor type	UL number	Classification
MKE037:	E203009	Class I, Groups C and D
MKE047:	E203009	
MKE098	E203009	

Fig. 9-6: Type tests MKE motors.

**Certificate of employment
Yellow Cards**

For all MKE motors are Yellow cards available, which confirm the structure and the compliance of the applicable US standards. If necessary, these Yellow cards can be requested from the pertinent sales office.

Note: It is allowed to use the MKE motors of type 037, 047 and 098 only in connection with the drive devices of Bosch Rexroth AG within hazardous areas.

When mounting the drive-devices in hazardous areas, the following components must fulfill the Ex-protection requirements.

motor with attached parts

Into the hazardous area leading current circuits

Hazardous area

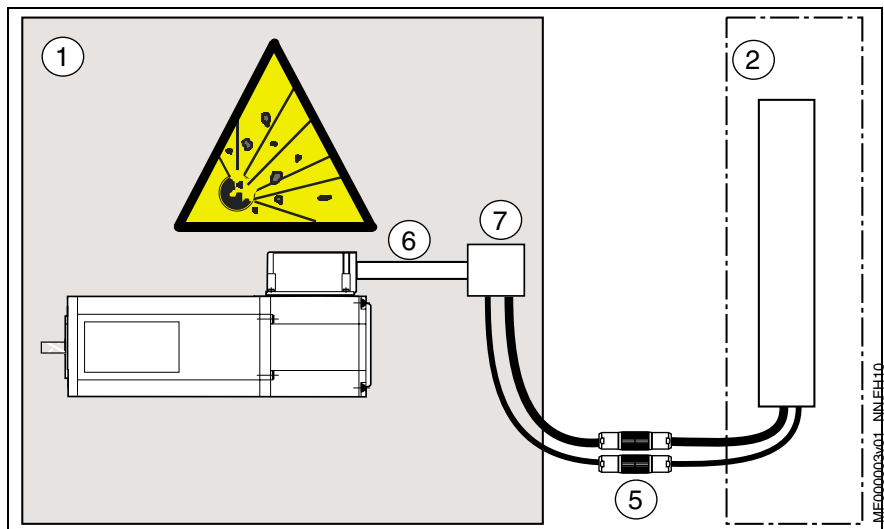

- (1): Hazardous area with explosion protected apparatus
- (2): control cabinet
- (3): drive device
- (4): MKE motor
- (5): Connections (optional)
- (6): Connection cables in a steel pipe.
- (7): Ex-terminal box (not included in scope of delivery)

Fig. 9-7: explosion-endangered area

Use in Class I The described MKE motors are UL listed and are allowed to be used in hazardous areas according to Class I, Groups C and D.

The relating drive devices and connections of the connection cables (power and feedback connection) must lay outside of the hazardous area.



DANGER

Danger of explosion, danger to life, heavy injury and property damage

- ⇒ Do not set up drive devices and connectors in hazardous areas.
 - ⇒ Make sure that connectors could not reach into the hazardous areas.
 - ⇒ Do not disconnect the connections under load!
 - ⇒ Make sure that no ignition sparks could occur within the hazardous area.
-

9.2 Setup Height and Ambient Temperature

Nominal data The performance data specified for the motors apply in the following conditions:

Ambient Temperature of 0 °C up to +40 °C
Setup Height 0 m up to 1000 m above MSL.

Exceeding the nominal data Derating curves If you intend to use motors above these ranges, you must take the “utilization factors” into consideration. This reduces the performance data.

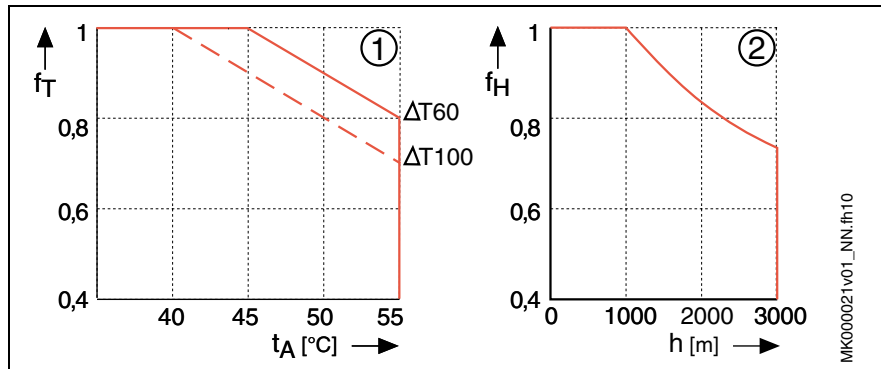

(1): Utilization depending on the ambient temperature

(2): Utilization depending on the site altitude

f_T: Temperature utilization factor

t_A: Ambient temperature in degrees Celsius

ΔT60 / ΔT100: Mode of operation

f_H: Height utilization factor

h: Site altitude in meters

Fig. 9-8: MKE derating (utilization factors)

If **either** the ambient temperature **or** the site altitude exceeds the nominal data:

1. Multiply the torque data specified in the selection data by the utilization factor.
2. Ensure that the reduced torque data are not exceeded by your application.

If **both** the ambient temperature **and** the setup height are exceeding the nominal data:

1. Multiply the determined utilization factors f_T and f_H by each other.
2. Multiply the value obtained by the motor torque data specified in the selection data.
3. Ensure that the reduced torque data are not exceeded by your application.

9.3 Protection class

The type of protection is defined by the identification symbol IP (International Protection) and two code numbers specifying the degree of protection.

The **first code number** defines the degree of protection against contact and penetration of foreign particles. The **second code number** defines the degree of protection against water.

First characteristic numeral	Degree of protection
6	Protection against penetration of dust (dust-proof); complete shock protection
Second characteristic numeral	Degree of protection
5	Protection against a water jet from a nozzle directed against the housing from all directions (jet water)

Fig. 9-9: IP degrees of protection



Tests regarding the second characteristic numeral must be performed using fresh water. If cleaning is effected using high pressure and/or solvents, coolants, or penetrating oils, it might be necessary to select a higher degree of protection.

The design of the MHE motors complies with the following degrees of protection according to DIN VDE 0470, Part 1, ed. 11/1992 (EN 60 529):

Motor range	Protection class	Remark
Motor housing, output shaft, power and encoder connectors (if mounted properly only)	IP 65	Standard design

Fig. 9-10: Ranges of IP degrees of protection for the motors

9.4 Compatibility

All Rexroth controls and drives are developed and tested according to the state-of-the-art.

However, as it is impossible to follow up the permanent new development of all material which may come into contact with our controllers and drives (e.g. lubricants for machine tools), we cannot generally exclude any reaction with the materials used in our systems.

For this reason, you will have to carry out a test on compatibility among new lubricants, detergents, etc. and our housing and device materials.

9.5 Design and Installation Positions

MKE motors are available in design B05. Please refer to the table below for the types of installation permissible according to EN 60034-7:1993.

Motor design	Permissible types of installation		
	Description	Sketch	Setup
B05	IM B5		Flange attached on the drive side of the flange
	IM V1		Flange attached on the drive side of the flange; drive side pointing down
	IM V3		Flange attached on the drive side of the flange; drive side pointing up

Fig. 9-11: Mounting position



DANGER

Penetration of fluids! If motors are attached according to IM V3, fluid present at the output shaft over a prolonged time may enter into and cause damage to the motors.

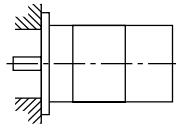
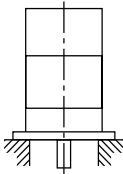
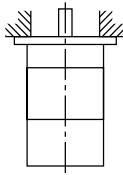
⇒ For that reason, ensure that fluid cannot be present at the output shaft.

9.6 Prime Coat and Housing Varnish

State upon delivery: Prime coat black in a/w RAL 9005

Resistance: Against weather, coloring, chalking, diluted acids and diluted lyes

It is not permitted to provide the housing with additional varnish (coat thickness no more than 40 µm).

9.7 Vibration and Shock Loads

MKE motors can carry loads, such as are typically occurring in case of presses, punches, or press inlets, only if they are attached in a shock-absorbed or shock-decoupled way. The construction of such attachments must be checked in isolated cases.

According to IEC 721-3-3 ed. 1987 and EN 60721-3-3 ed. 06/1994, MKE motors, if used stationary and weather-resistant, may be operated under the following conditions:

Longitudinal motor axis: according to Class 3M1

Transverse motor axis: according to class 3M4

Ensure that the limits specified in Fig. 9-12: Limits for sinusoidal vibrations

and Fig. 9-13: Limits for shock load

for storage, transport, and operation of the MKE motors are not exceeded.

Influencing quantity	Unit	Maximum value in longitudinal axis	Maximum value in transverse axis
Amplitude of the excursion at 2 to 9 Hz	mm	0,3	3,0
Amplitude of the acceleration at 9 to 200 Hz	m/s ²	1	10

Fig. 9-12: Limits for sinusoidal vibrations

Influencing quantity	Unit	Maximum value in longitudinal axis	Maximum value in transverse axis
Total shock-response spectrum (according to IEC721-1, :1990; Table 1, Section 6)		Type L	type I
Peak acceleration	m/s ²	40	100
Duration	ms	22	11

Fig. 9-13: Limits for shock load

9.8 Output shaft and shaft sealing ring

Smooth shaft

The standard design recommended for MKE motors provides a friction-locked shaft-hub connection without play and excellent running smoothness. Use clamping sets, clamping sleeves or clamping elements to couple the machine elements to be driven.

Output shaft with fitting key

The optional fitting spring according to DIN 6885, Sheet 1, version 08-1968, permits keyed transmission of torques with constant direction, with low requirements for the shaft-hub connection.

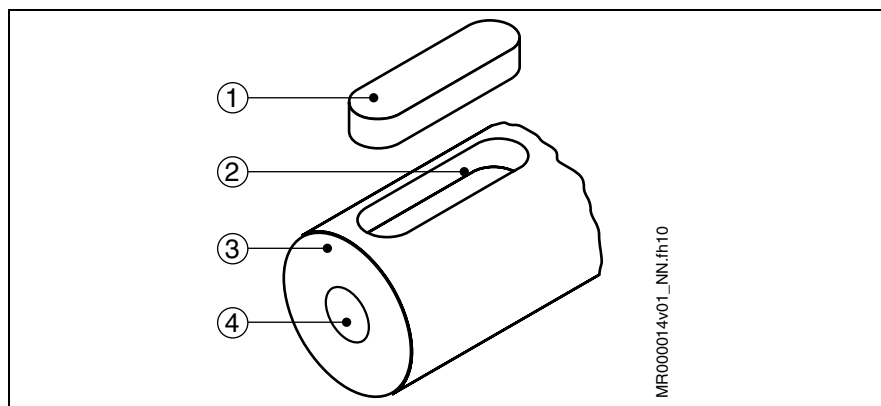

- (1): Fitting spring
- (2): Fitting spring groove
- (3): Motor shaft
- (4): Centering hole

Fig. 9-14: MKE output shaft with featherkey

The machine elements to be driven must additionally be secured in the axial direction via the centering hole on the end face.



CAUTION

Shaft damage! In case of intense reversing operation, the seat of the featherkey may deflect. Increasing deformations in this area can then lead to a break of the shaft!

⇒ Preferably, plain output shafts should be used.

Balancing with a complete fitting spring

MKE motors are balanced with the **complete** featherkey. Hence, the machine element to be driven must be balanced without a fitting spring.



Modifications to the fitting springs may be made only by the user himself and on his own responsibility. Bosch Rexroth do not give any warranty for modified featherkeys or motor shafts.

Output Shaft With Shaft Sealing Ring

MKE motors are designed with radial shaft sealing rings according to DIN 3760 – design A.

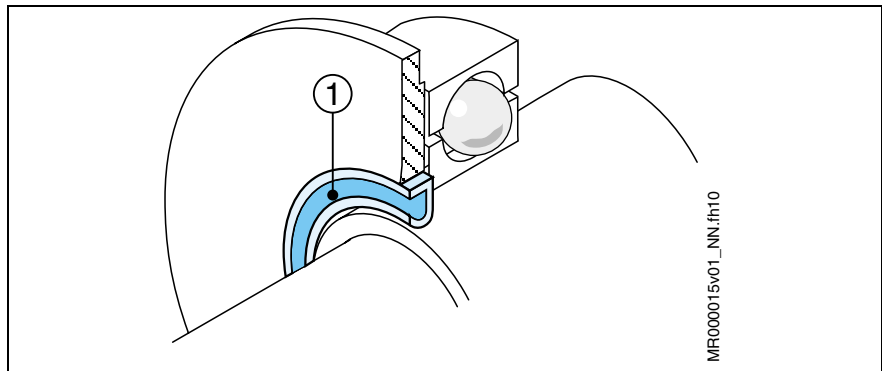

(1) Radial shaft sealing ring

Fig. 9-15: MKE radial shaft sealing ring

Wear Radial shaft sealing rings are rubbing seals. Hence, they are subject to wear and generate frictional heat.

Wear of the rubbing seal can be reduced only if lubrication is adequate and the sealing point is clean. Here, the lubricant also acts as a coolant, supporting the discharge of the frictional heat from the sealing point.

⇒ Prevent the sealing point from becoming dry and dirty. Always ensure adequate cleanliness.

Note: Under normal environmental conditions the shaft seal is greased for lifetime. Under unfavourable environmental conditions (e.g. grinding dust, scops) maintenance could be necessary.

Resistance The materials used for the radial shaft sealing rings are highly resistant to oils and chemicals. The performance test for the particular operating conditions lies, however, within the machine manufacturer's responsibility.

As of the publication date of this document, the following material assignment is applicable:

Motor	Sealing material	Short name
MKE	Fluorocautchouc	FPM (Viton)

Fig. 9-16: MKE shaft sealing ring



The complex interactions between sealing ring, shaft and fluid to be sealed as well as the particular operating conditions (frictional heat, soiling, etc.) do not allow calculation of the lifetime of the shaft sealing ring.

**Vertical installation positions
IM V3** The degree of protection on the flange side of motors with a shaft sealing ring is IP 65. Hence, tightness is ensured only in case of splashing fluids. Fluid levels present on side A require a higher degree of protection. If the motor is installed in vertical position (shaft pointing up), the instructions in the section "Design and Installation Positions" in this chapter must, in addition, be observed.

Note on construction Bosch Rexroth recommend that any direct contact of the output shaft and the radial shaft sealing ring with the processing medium (coolant, material corrosion), caused by the type of machine or system construction, should be avoided.

9.9 Bearings and Shaft Load

During operation, both radial and axial forces act upon the motor shaft and the motor bearings. The construction of the machine, the selected motor type and the attachment of driving elements on the shaft side must be adjusted to one another to ensure that the load limits specified are not exceeded.

Radial load, axial load

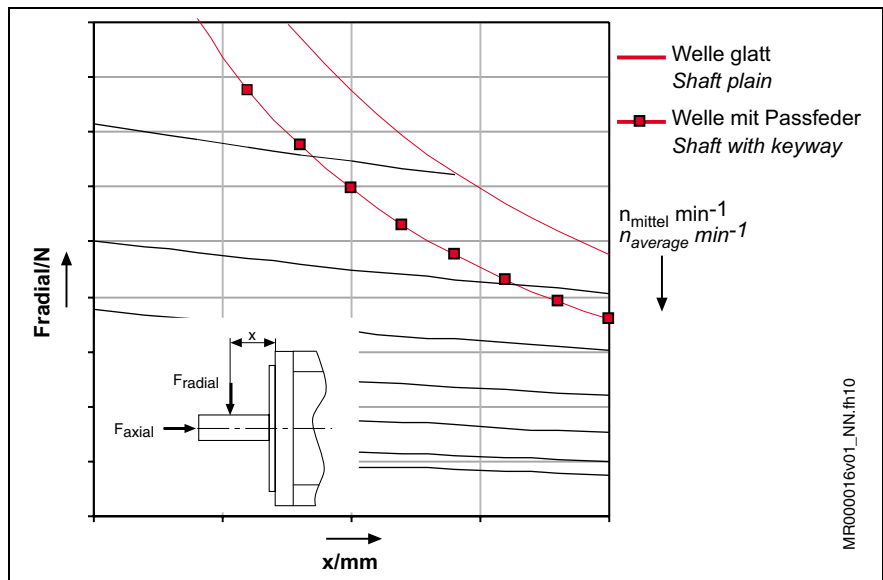

Fig. 9-17: Example of a shaft load diagram

Maximum permissible radial force $F_{\text{radial_max}}$

The maximum permissible radial force $F_{\text{radial_max}}$ depends on the following factors:

- Shaft break load
- Point of application of force x (see chapter "Technical Data")
- Shaft design (plain; with keyway)

Permissible radial force F_{radial}

The permissible radial force F_{radial} depends on the following factors:

- Arithmetic mean speed (n_{mean})
- Point of application of force x (see chapter 4 "Technical Data")
- Bearing Service Life

Permissible axial force F_{axial}

The maximum permissible axial force F_{axial} is proportional to the radial force. Please refer to the section entitled "Shaft load" in the technical data for the proportionality factor.

Mean speed The run-up and braking times can be ignored in the calculation if the time in which the drive is operated at a constant speed is significantly greater than the acceleration and braking time. In the exact calculation of the mean speed according to the following example, the run-up and braking times are taken into account.

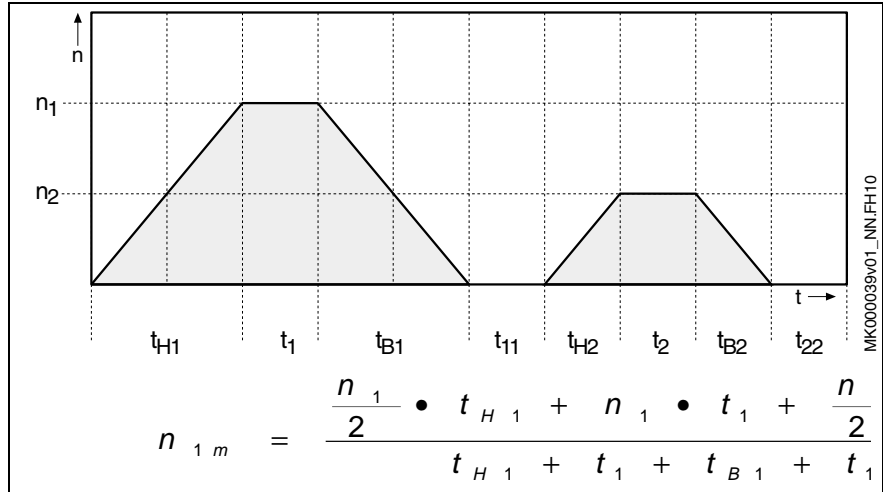

- | | | | |
|------------|-------------------------|------------|-------------------------|
| n_{1m} : | mean speed in section 1 | n_{2m} : | mean speed in section 2 |
| n_{1m} : | processing speed | n_2 : | processing speed |
| t_{H1} : | run-up time | t_{H2} : | run-up time |
| t_1 : | processing time | t_2 : | processing time |
| t_{B1} : | braking time | t_{B2} : | braking time |
| t_{11} : | standstill time | t_{22} : | standstill time |

Fig. 9-18: Mean speed

A complete processing cycle can consist of several sections with different speeds. In this case, the average is to be generated from all the sections.

Attachment of drive elements

For all attachments of drive elements to the drive shaft, as e.g.

- transmissions
- couplings
- pinions

it is imperative that the following notes are observed.

Redundant bearing Generally, redundant bearing is to be avoided by all means when connecting drive elements. The tolerances inevitably present in such cases will lead to additional forces acting on the bearing of the motor shaft and, should the occasion arise, to a distinctly reduced service life of the bearing.

Note: If redundant attachment cannot be avoided, it is absolutely necessary to consult with Bosch Rexroth.

Couplings The machine construction and the drive elements used must be carefully adapted to the motor type so that the loading limits of the shaft and the bearing are not exceeded.

Note: When connecting extremely stiff couplings, the radial force which constantly changes the angular position may cause an impermissibly high load on shaft and bearing.

Bevel gear pinion or helical drive pinion Owing to thermal effects, the flange-sided end of the output shaft may shift by 0.6 mm in relation to the motor housing. If skew bevel driving pinions or bevel gear pinions directly attached to the output shaft are used, this change in position will lead to

- a shift in the position of the axis, if the driving pinions are not defined axially on the machine side,
- to a thermally dependent component of the axial force, if the driving pinions are defined axially on the machine side. This causes the risk of exceeding the maximum permissible axial force or of the play within the gearing increasing to an impermissible degree.

Note: In such cases, you should therefore, preferably use drive elements with their own bearings, which are connected to the motor shaft via axially compensating couplings.

Bearing lifetime

The bearing lifetime is an important criterion for the availability of MKE motors. When the lifetime is considered, the "mechanical lifetime" of bearing components and material is differentiated from the "grease lifetime" of the bearing lubricant.

If the MKE motors are operated within the limits specified for radial and axial loads, the nominal service life of the bearings is as follows:

The mechanical service life of the bearings is as follows:

Mechanical service life of bearings

$L_{10h} = 30.000$ operating hours
(calculated according to ISO 281, ed. 12/1990)

This applies to all MKE motors based on the following:

- The permitted loads from the corresponding chapter "Technical Data" are never exceeded.
- The motor is operated under the permitted conditions for use and in the permitted ambient temperature range of 0° to +40° C.
- The "mean speed" driven over the entire processing cycle conforms with the characteristic curves for the grease lifetime from the corresponding chapter "Technical Data" , whereby:

$$n_m < n_{m(t_f = 30000 \text{ h})}$$

n_m : mean speed

$n_{m(t_f)}$: mean speed for which a grease lifetime of 30000 h can be expected.

Fig. 9-19: mean speed

Differing loads can have the following effects:

- Premature failure of the bearing due to increased wear or mechanical damage.
- Reduction of the grease lifetime, leading to premature failure of the bearing.

⇒ Avoid exceeding the load limits.

Mechanical service life with increased radial force

In other cases, the bearing service life is reduced as follows:

$$L_{10h} = \left(\frac{F_{radial}}{F_{radial_ist}} \right)^3 \cdot 30000$$

L_{10h} : (Bearing service life according to ISO 281, ed. 12/1990)

F_{radial} : Determined permissible radial force in N (Newton)

F_{radial_ist} : Actually acting radial force in N (Newton)

Fig. 9-20: Calculation of the bearing service life L_{10h} if the permissible radial force F_{radial} is exceeded

Note Under no circumstances may the actually acting radial force F_{radial_ist} be higher than the maximum permissible radial force F_{radial_max} .

9.10 Holding Brakes

Use the brake in **normal operation** only at a standstill and when performing the drive-internal brake check. The holding brake is required for holding the axle when the machine is in a de-energized state.



Hazardous movements! Persons endangered by falling or descending axles!

⇒ Observe supplementary DIN and recommendations.
For European countries:

- DIN EN 954 / 03.97 on security-related parts of controllers.
- Instruction sheet for vertical axes

Issued by:

Süddeutsche Metall-Berufsgenossenschaft
Fachausschuss Eisen und Metall II
Wilhelm-Theodor-Römheld-Str. 15
55130 Mainz, Germany

USA: See National Electric Code (NEC), National Electrical Manufacturers Association (NEMA) as well as local building regulations.

The following is generally valid: The national terms must be observed!

- ⇒ The serially delivered motor holding brake does not suffice to ensure protection of persons!
- ⇒ Ensure protection of persons by superordinate fail-safe measures.
- ⇒ Cordon off the hazardous area by means of a safety fence or a safety screen.
- ⇒ Additionally secure vertical axes to prevent them from falling or descending after having switched off the motor, for instance as follows:
 - lock the vertical axis mechanically,
 - provide an external braking / collecting / clamping device, or
 - ensure proper weight compensation of the axis.
 - Miscellaneous suitable measures.

Brake control

The brake's control mechanism must ensure this function in normal operation. Under the worst load condition of the power supply with a voltage of $24 V_{DC} \pm 10\%$ must be supplied to the motor. To identify a failure on time during operation, the power supply for the brakes must be monitored by an undervoltage detection system.

Functional test Before start-up and during operation specifications the brake function must be tested with the "brake command" function. By applying a small amount of motor torque, the brake is tested for slippage. Additional information and specifications of this function may be found in the ECODRIVE firmware functional descriptions.

Selecting Holding Brakes

Brakes are either electrically clamping or electrically releasing. Due to functional differences, different brakes should be used for main spindle and servo-axes. Observe the safety requirements during the plant design.

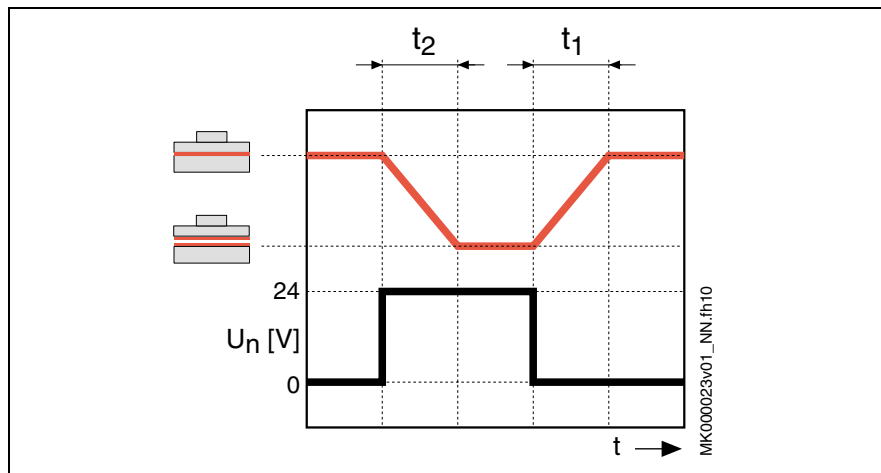

t_1 : Clamping delay

t_2 : Release delay

Fig. 9-21: Holding brake diagram

Servo application

Electrically releasing holding brake

The **electrically releasing** holding brake is used to hold the axes at a standstill and when the "controller enable" signal is off. When the supply voltage fails and the controller is enabled, the **electrically releasing** brake will automatically close.

⇒ Do not use the holding brake as an operational brake for moving axes.

If the brake is engaged repeatedly on a drive in motion or the rated brake torque is exceeded, premature brake wear can occur.

Sizing of Holding Brakes (Application)

The physical conditions of holding brakes require consideration of two states. Beyond the normal operation also the incident must be viewed. The effective braking torques are physically different.

Normal Operation

In normal operation, using the holding brake for clamping of an axis standstill, the brake's static torque (M_4) rating in the data sheets applies directly as static friction (M_4) – stiction (friction coefficient μ_H).

Fault Condition (EMERGENCY STOP)

In **fault conditions (i.e., EMERGENCY STOP)**, where the holding brake is used to stop a moving axis, the "dynamic braking torque", or sliding friction (friction factor μ_G) applies.

The dynamic braking torque is reduced in comparison to the indicated static holding torque M_4 . Therefore, note the following description of dynamic sizing.

Dynamic sizing The load torque must be smaller than the minimum dynamic torque which the brake can provide. Otherwise the dynamic brake torque is not sufficient to stop the axis.

If a mass should be decelerated in a defined time or in a defined way, the additional moment of inertia of the whole system must be taken into account.

Further important aspects for sizing:

The holding brake is not a safety brake (see DIN EN 954 / 03.97 and vertical axis data sheet SMBG). As a result of uncontrollable influencing factors such as rust film on the brake surface, the brake holding torque can be reduced. Additionally, excessive voltage and temperature can weaken the permanent magnets and the brake.

Sizing recommendation Bringing these factors together, the following recommendations can be given for sizing the holding brakes to the axles.

The necessary holding torque required for the application must not exceed a maximum of 60% of the static holding torque (M_4) of the used holding brake.

Note: Holding torque reduction and premature wear occur when braking moving axles!

Do not use the holding brake to stop a moving axle! This is permitted for EMERGENCY STOP situations only. In this situation, the specified rated torque of the holding brake (M_4) is reduced to the value of the available dynamic braking torque. Complete deterioration of brake holding capability can be expected after approximately 20,000 revolutions of the brake when clamped.

Observe the instructions on commissioning holding brakes as described in the chapter "Startup, Operation, and Maintenance".

9.11 Acceptance and allowance

Motors in EU style

Declaration of conformity Declarations of conformity certifying the structure of and the compliance with the applicable EN standards and EC guidelines are available for all MKE motors. If necessary, these declarations of conformity can be requested from the pertinent sales office.

The CE-symbol and Ex-designation can be seen on the type plates of the MKE Motors.

CE symbol



Fig. 9-22: CE symbol

Ex mark



Fig. 9-23: Ex mark

Motors in UL style

UL, CSA Listing

The MKE motors listed below have been presented to the UL authorities "Underwriters Laboratories Inc.®".

- MKE037B
- MKE047B
- MKE098B

The motors have been approved by the UL authorities under the file number **E203009** and have been marked on their motor type label with the following sign:



Fig. 9-24: cUR mark

10 Handling, Transport and Storage

10.1 Supplied Condition

On delivery are the MKE motors packed in cardboard boxes or crates. Packing units on pallets are secured by retaining straps.



WARNING

Injuries due to uncontrolled movement of the retaining straps when cutting!

⇒ Maintain a sufficient distance and carefully cut the retaining straps.

On delivery ex works the motor drive shaft and the connectors have protective caps. Remove the protective sleeves just before assembly.

Factory-attached test

All MKE motors undergo the following inspections, among others, at the factory:

Electrical inspection

- High voltage test according to DIN EN 60034-1/02/99
- Insulation resistance according to EN 60204-1/1.92, Section 20.3.
- Protective connection according to EN 60204-1/1.92, Section 20.3.
- Test winding resistance

Mechanical inspection

- Concentricity and position tolerances of shaft end and fastening flange according to DIN 42955/12.81
- Axial eccentricity of the flange face to the shaft according to DIN 42955/12.81.
- Axial eccentricity of the centering shoulder to the shaft according to DIN 42955/12.81.
- Test brake holding torque (option)

Test on the customer side

Since all MKE motors undergo a standardized inspection procedure, high-voltage inspections by the customer are not required. Motors and components could be damaged if they undergo several high-voltage inspections.



DANGER

Destruction of motor components by improperly executed high-voltage inspection! Invalidation of warranty!

- ⇒ Avoid repeated inspections.
- ⇒ Observe the regulations of EN 60034-1 (= VDE 0530-1).

10.2 Identification

Shipping documents and delivery note

The total scope of a delivery can be seen in the delivery note or waybill. However, the contents of a delivery can be distributed over several packages.

Each individual package can be identified using the shipment label attached to the outside.

Name plate

Each device has an individual name plate containing the device designation and technical information.

⇒ After receiving the goods, compare the ordered and the supplied type. Submit claims concerning differences immediately.

Motor The motor is delivered including a name plate. This name plate is attached to the motor housing. In addition, a second type label is adhered onto the original name plate on the motor housing, using double-sided adhesive tape. The latter name plate can be put easily-visible on the machine, if the original name plate on the motor be concealed by parts of the machine.

Because of different national guidelines, different type plates are used for motors according to EN and UL-standards. The differences are shown in the following picture.

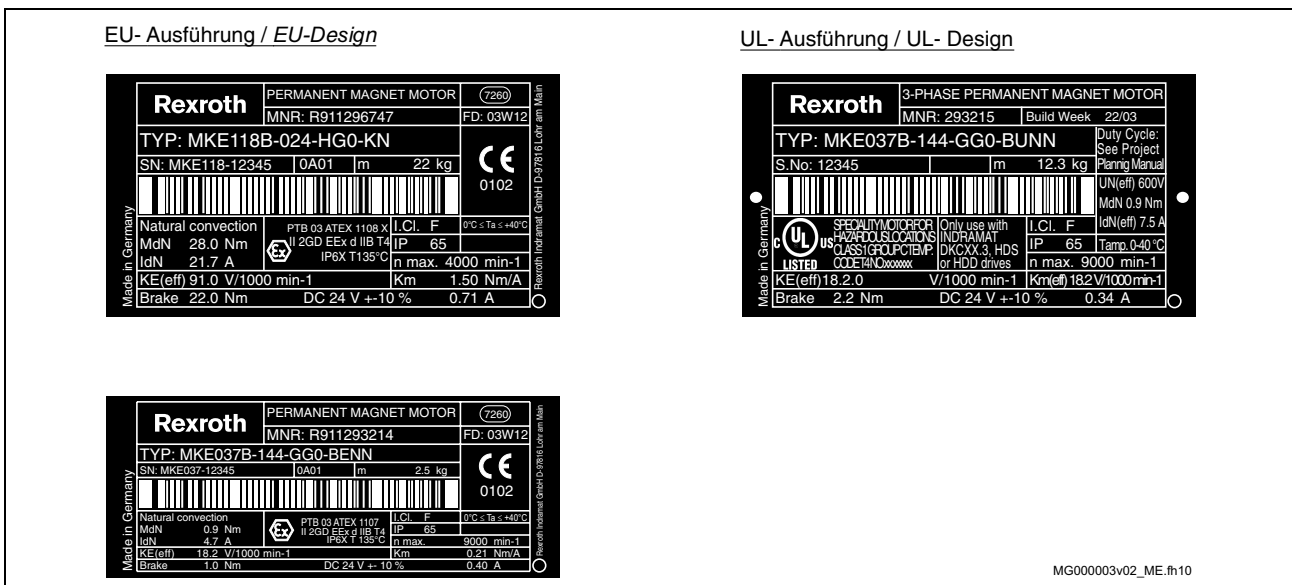

Fig. 10-1: Name plate (example MKE)

The name plate is provided for identification of the motor, procurement of spare parts in case of a failure, service information.

Note: The name plate of the motor is also filed in the encoder data memory.

10.3 Transport and storage



CAUTION

Damages or injuries and invalidation of the warranty due to improper handling!

- ⇒ Avoid mechanical stressing, throwing, tipping or dropping of the products.
- ⇒ Use only suitable tackles.
- ⇒ Never lift the motor out of the optional blower housing.
- ⇒ Use suitable protective equipment and protective clothing during transport.
- ⇒ Protect the products from dampness and corrosion.

Also observe the notes regarding storage and transport on the packages

Delivery

On delivery the MKE motors have protective caps and covers on the output shaft and on the flange sockets. During transport and storage, the protective sleeves must remain on the motor.

- ⇒ Remove the protective sleeves just before assembly.
- ⇒ Also use the protective sleeves if you return the goods.

Transport

The following conditions must be kept during transport:

- ⇒ Use suitable means of transport and consider the weight of the components (you can find the weight information on the data sheets or on the name plate of the motor).
- ⇒ Provide for shock absorption, if strong vibrations may occur during transport.
- ⇒ Transport the motors only in horizontal position.
- ⇒ Use cranes with lifting sling belts to lift the motors.
- ⇒ Avoid damage on the motor flange and drive shaft.
- ⇒ Refrain beats on the drive shaft.

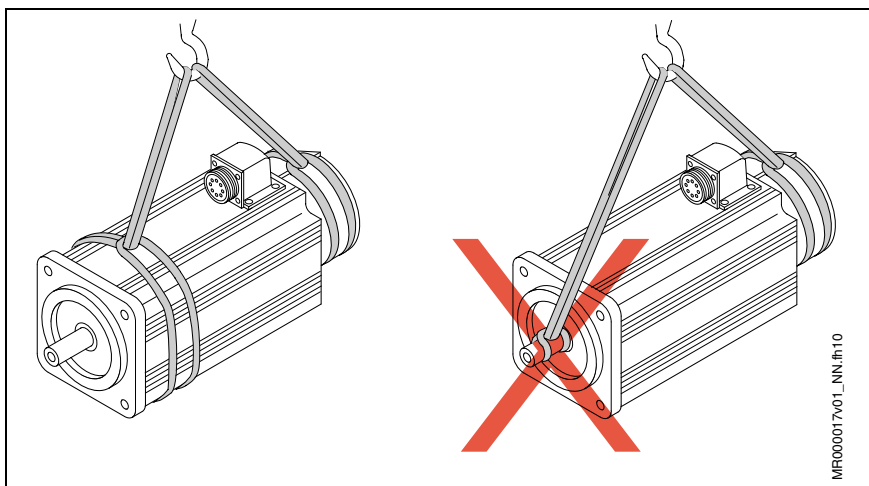

Fig. 10-2: Lifting and transporting the motors by means of lifting sling belts

Bearing



CAUTION

Damage and loss of the warranty by incorrect storage!

- ⇒ Store the motors dry, vibration-free, dust-free and corrosion-protected in horizontal condition
- ⇒ Permittable temperature range -20°C to $+80^{\circ}\text{C}$.

11 Installation

11.1 Safety



WARNING

Injuries due to live parts! Lifting of heavy loads!

- ⇒ Install the motors only when they are not under power and not connected electrically.
- ⇒ Use suitable tackles, protective equipment and protective clothing during transport.
- ⇒ Observe the notes regarding safety found in previous chapters.

Carry out all working steps especially carefully. In this way, you minimize the risk of accidents and damages.

11.2 Skilled technical personnel

Any work on the system and on the drives or in their vicinity may only be carried out by appropriately trained technical personnel.

Please make sure that all persons doing

- installation work,
- maintenance, or
- operational activities

on the system are adequately familiar with the contents of this documentation as well as with all warnings and precautionary measures contained therein.



Qualified technical personnel are defined as those, who have been trained, instructed or are authorized to activate and deactivate, ground and mark electric circuits and equipment according to the safety rules and regulations. Qualified technical personnel must possess appropriate safety equipment and have been trained in first aid.

11.3 Mechanical mounting – Motor assembly

Mounting the flange

MKE motors are produced for flange mounting (size B05) according to DIN 42950 part 1, Edition 08.77. Details for the fastening holes can be found in the corresponding dimension sheet.

To fix the flange, we recommend to use the screws and tightening torques listed in the table below.

Motor Frame Size	Recommended screw size	Tightening torque [Nm]	Minimum strength
MKE037:	4x M4	3,1	8.8
MKE047:	4 x M6	10,4	8.8
MKE098	4 x M10	51	8.8
MKE118	4 x M12	87	8.8
Use only hexagon socket screws according to DIN EN ISO 4762 with minimum resistance 8.8!			

Fig. 11-1: Locking screws

Note: The screwed connections must be able to take up both the force due to the weight of the motor and the forces acting during operation.

Preparation

Prepare motor assembly as follows:

1. Procure tools, auxiliary materials, measuring and test equipment.
2. Proof all components if they are obviously damaged. Defective components may not be mounted.
3. Ensure that dimensions and tolerances on the system side are suitable for motor attachment (for details, see the dimension sheet).
4. Check whether all components, assembly surfaces and threads are clean.
5. Ensure that mounting can be done in a dry and clean environment.
6. Ensure that the holder for the motor flange is without burrs.
7. Remove the protective cap of the motor drive shaft and keep it for further use.
8. Check whether the motor holding brake reaches the holding torque specified in the data sheet. Should the brake fail to reach the torque specified, first grind in the holding brake as described under the "Holding Brake" section in Chapter 12.4.

If the optional holding brake is used

Assembly

⇒ Assemble the motor.

Note:

1. Avoid pinching or jamming the centering bundle on the motor side.
2. Avoid damage to the insertion fitting on the system side.
3. Check the fit and precision of the connection before you proceed.

After proper mechanical assembly, make the electrical connections.

11.4 Electrical connection – Motor connection

It is recommended that you use ready-to-use Rexroth connection cables. These cables provide a number of advantages, such as UL/CSA approval, extreme load capability and resistance as well as a design suitable for EMC.



DANGER

Danger to life by electric voltage! Handling within the range of live parts is extremely dangerous. Therefore:

Any work required on the electric system may only be carried out by skilled electricians. It is absolutely necessary to use electric tools.

Before starting work, the system must be de-energized and the power switch be secured against unintentional or unauthorized re-energization.

Before starting work, the appropriate measuring equipment must be used to check whether parts of the system are still applied to residual voltage (e.g. caused by capacitors, etc.). If yes, wait until these parts have discharged.



WARNING

Injuries to persons or property are possible! Interrupting or connecting live lines may cause unpredictable dangerous situations or lead to physical damage. Therefore:

⇒ Connect and disconnect plug connectors only when they are dry and de-energized.

⇒ During operation of the system, all plug connectors must be securely tightened.



WARNING

Risk of short-circuit caused by liquid coolant or lubricant! Short-circuits of live lines may cause unpredictable dangerous situations or lead to physical damage. Therefore:

Provide open mating sides of power plug connectors with safety caps when installing or replacing drive components, if you cannot exclude that they might be moistened with liquid coolant or lubricant.

Motor connection according to European standard (EN)

MKE037, -047, -098



WARNING

Damages on connection box or at the cable are possible!

Too high tightening torque can damage the screw fastenings or lead to cable crushings. If bolt-on fixings are damaged, the protection IP65 on the terminal box cannot be ensured any longer.

In fact of this use no automatic screwdriver (e.g. electrical, pneumatic or hydraulic screwdriver).

The MKE motors are provided with a terminal box. When connecting the motor, cables, which are according to the ready-made cables of Rexroth, have to be used. The cables have to be assembled as follows:

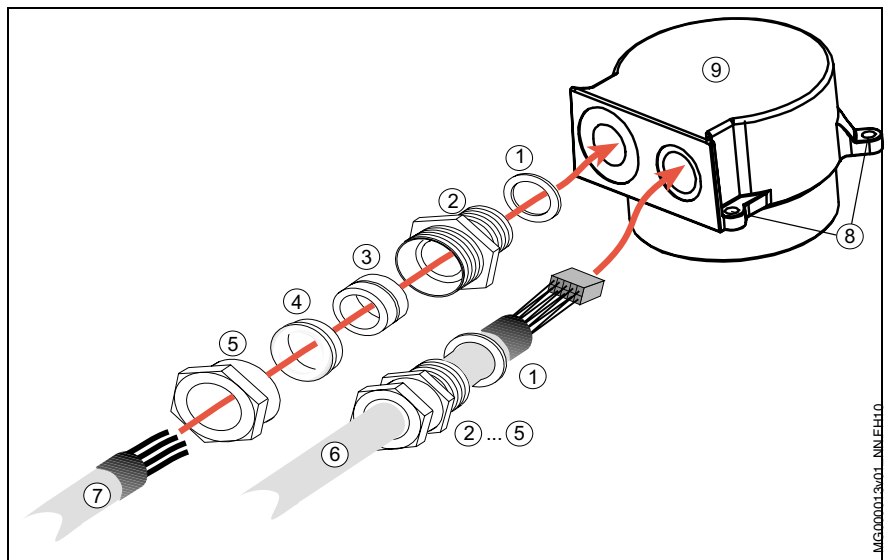

- 1: Sealing
- 2: screwing
- 3: cable sealing
- 4: Pressure piece
- 5: Union nut
- 6: Encoder cable
- 7: Power cables
- 8: Lid screws
- 9: Terminal box lid

Fig. 11-2: Connection of MKE037, -047, -098

Remove terminal box lid

1. Remove the lid screws (8) and take off the terminal box lid (9).

Note:

The lid screws are coated with TFL. By screwing in resp. out of lid screws, the coating will be destroyed. When assembling the terminal box lid, use only the added, coated lid screws.



The EExd-Cable screwings are mounted factory-attached. The sealing (1) is screwed with with the screwing (2) on the terminal box lid (9) (tightening torque of Nm). - The terminal box includes the complete accessory incl. assembly instruction.

- | | |
|--|--|
| Thread the power cable | <p>2. Insert the union nut (5), the pressure piece (4) and the cable sealing (3) in the indicated order over the power cable (7)</p> <p>3. Tighten the screwing (2) with the sealing (1) within the terminal box lid (9) with tightening torque of 50 Nm.</p> <p>4. Insert the power cable (7) through the screwing (2) into the terminal box lid (9).</p> |
| Thread the encoder cable | <p>5. Remove the EExd-Cable screwing for the encoder cable.</p> |
| <p>Note: When using the ready-made cables of Rexroth, the EExd cable screwing on the motor is not needed.</p> | |
| Tighten the EExd-screwing | <p>6. Insert the encoder cable (6) into the terminal box lid (9) (see Fig. 11-4).</p> <p>7. Tighten the screwing of the encoder cable (2) with the sealing (1) within the terminal box lid (9) with tightening torque of 50 Nm.</p> <p>8. Pull back the cable until the shrinking sleeve penetrates the inside of the connection box by about 16mm (see Fig. 11-4).</p> <p>9. Tighten the union nuts (5) on the screwing (2) with an tightening torque of 15 Nm \pm10%.</p> |
| Connect the shield | <p>10. Connect the ring terminal (10) and (11) on X5 within the terminal box lid (9) (tightening torque 1,3 Nm \pm10%).</p> |
| Connect the power cable | <p>11. Connect the plug-in terminals X1 and X2 according to the connection plan (Fig. 11-3) on the power cable.</p> <p>12. Connect the plug-in terminals X1 and X2 into the appropriate position of the motor connection plate.</p> <p>13. Safe the plug-in terminals X1 with the connection screw of the printed-circuit board socket.</p> |
| Connect the encoder cable | <p>14. Mount the plug-in interlock on the encoder connector X3 (Fig. 11-3).</p> |

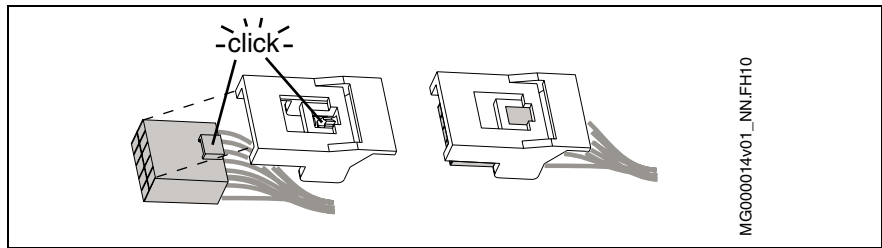

Fig. 11-3: Plug-in interlock

15. Connect the encoder connector X2 on the motor connection plate.

Mount the terminal box lid

16. Set the terminal box lid (9) on the motor. Make sure that no wire can be crushed or damaged.

17. Tighten the terminal box lid (9) with the added TFL-coated lid screws (8) with 6.1 Nm.

i If substitute is necessary, please use for lid screws (8) only IS-Screws according to DIN 4762 with a minimum consistency of 8.8!

Note: We recommend at repeated assembling of the terminal box lid, to secure the lid screws (8) with Loctite 243.

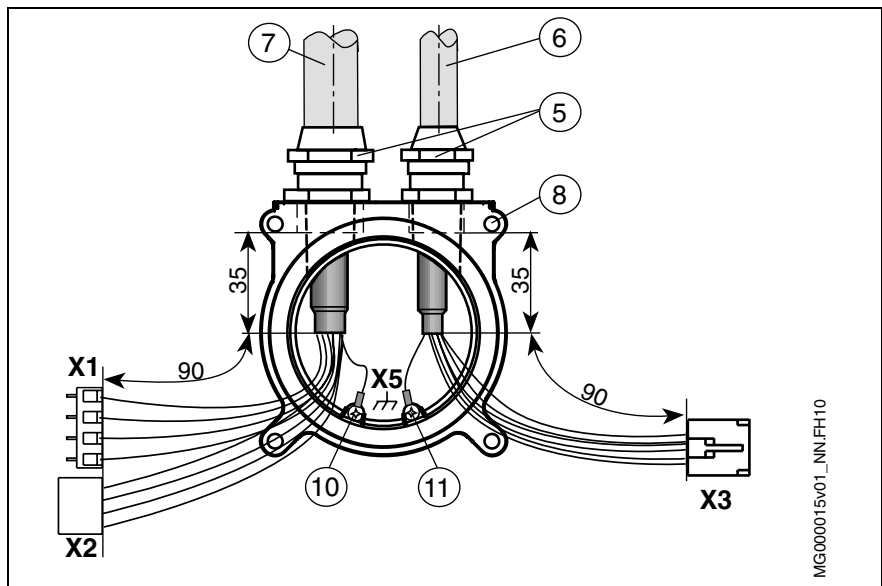

- (5): EExd-Cable screwing
- (6): Encoder cable
- (7): Power cables
- (8): Lid screw tighten torque 6.3 Nm
- (10),(11): Shield connection screw tighten torque 1.3 Nm
- X1: Plug-in terminal
- X2: Plug-in terminal brake, temperature
- X3: Encoder connector
- X5: Shield connection

Fig. 11-4: Entrance of power and conductor cables MKE 096

MKE118

Cable fittings MKE118/EU motors of Rexroth are to be connected with especially to the cable outer diameter matched Ex-threads.

Consider the notes of the manufacturer:

All cable entries of type **LE...** have to be included into the type check according to EN 50018, Section 15.1.3 (overpressure) the group classification of the particular electrical apparatus (group classification I, IIA, IIB or IIC), if the operating pressure exceeds 20 bar.

The cable entries must be fastened into the electrical apparatus in such a way that they are secured against twisting and self-loosening.

The cable entry include a multi-part set of sealing rings per nominal diameter of the cables. The fitting sealing ring has to be selected and the union nut has to be screwed as far as it will go.

When investigating the maximum current-carrying capacity of the connection wires assume the self-warming and housing-warming on the mounting place at maximum permitted environmental temperature.

Note: The explosion protection for the cable entries can only be guaranteed, when they are in their original condition. The explosion protection can no longer be guaranteed, if:

- the isolator is damaged, broken or flaking.
- The winding of the screw-grommet is damaged.
- The cleavage face of the assembling bolt was changed, processed or damaged.

Because of technical reasons, a repair can be done exclusively by the manufacturer.

Grommets have to be used at mounting, which are adjusted with the cable outer diameter in which the threads must be applied.

 KR000001v01_NN.FH10	Available grommets with nominal diameter tolerance -0.5mm						
	screwing						
LE20/9 (Encoder)	8,5	9,0	9,5				
LE26/15 (Power 2.5 mm ²)	13,5	14,0	14,5	15,0	15,5	16,0	16,5
LE26/19 (Power 6.0 mm ²)	17,5	18,0	18,5	19,0	19,5		

Fig. 11-5: Grommets for Ex-fittings

**DANGER****Danger of explosion, danger to life, heavy injury and property damage**

- ⇒ Only according to the rules mounted cable fittings hinder the penetration of hazardous gases/dusts.
- ⇒ Make sure that only grommets are used, which are adjusted to the cable diameter.

The following steps are necessary:

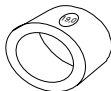
1. Collect the outer-diameter of the cable on the clamping of the cable fitting.

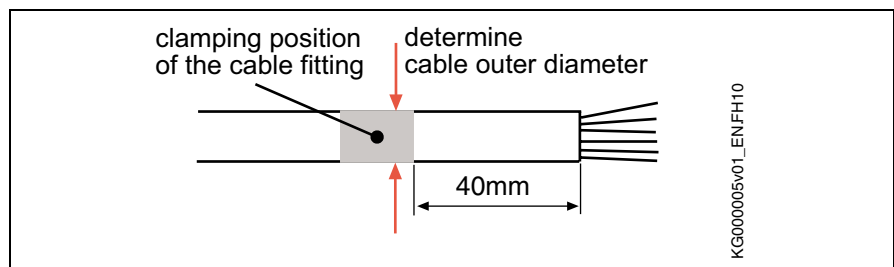

Fig. 11-6: Determine the cable outer diameter

2. Select the necessary grommet and mount it on the cable fitting.
3. Tighten the cable fitting as far as it will go.

The cable fittings are mounted according to the Ex-instruction.

Mount and connect ready-made cables

Ready-made cables are mounted according to Fig. 11-7.

When using ready-made encoder cables, remove the fitting, which is mounted on the motor and use the fitting, which is mounted on the cable.

It is not necessary to define the cable outer diameter, now.

Note: Do use only the following ready-made encoder cables for the connection on MKE118 motors: **IKS0225, IKS0226, IKS0227, IKS0228**. Only these cables have the necessary Ex-cable fitting.

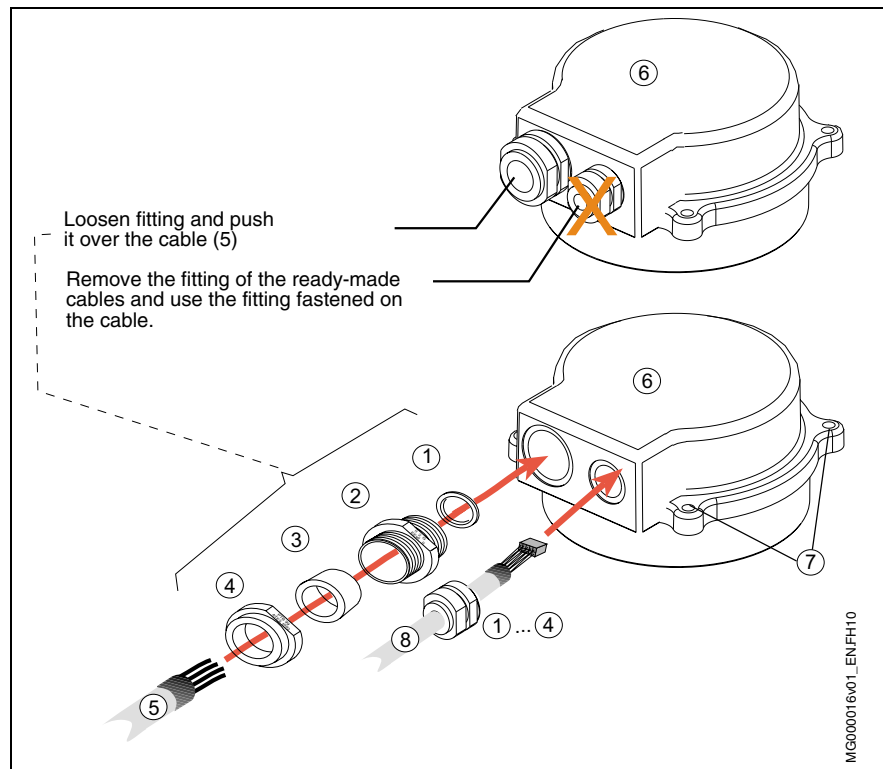

- (1): Sealing
 (2): screwing
 (3): Use grommets according to the cable diameter.
 (4): Union nut
 (5): Ready-made power cable
 (6): Terminal box lid
 (7): Lid screws
 (8): Ready-made encoder cable

Fig. 11-7: Mounting the EExd-fitting and cable MKE118

Note: Loosen and tighten the cable fittings is **not** permitted. In this cases, a new grommet is to be used.

The cables, which are thread into the terminal box have be connected as follows:

4. Use the connecting plan (see Fig. 8).
5. **Connect the shield.** Connect the ring terminal of the power and encoder cabel on the X5 within the terminal box lid (Tightening torque 1.3 Nm 10%)
6. **Connect the power cable.** Lay the wires according to the connection plan (Fig. 8-4) onto the terminal block X1 and X2.
7. **Connect the encoder cable.** Mount the connection lock onto the encoder connector X3.

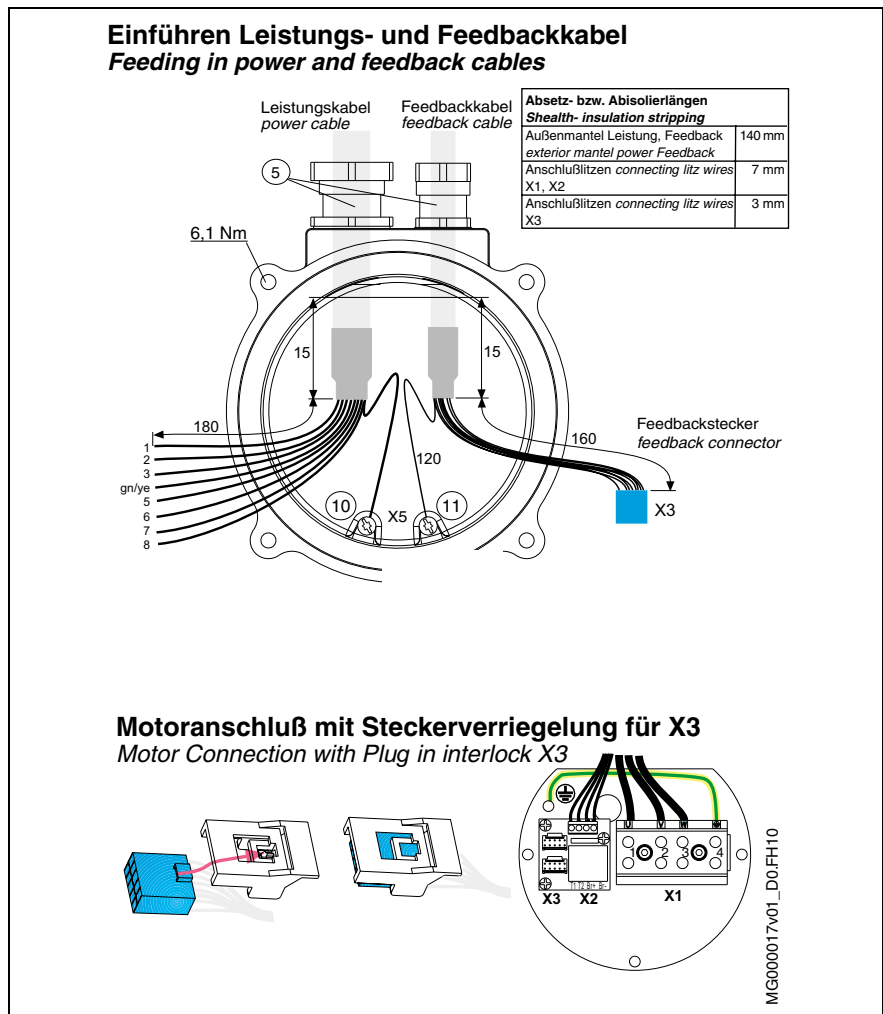

Fig. 11-8: Connection MKE118 encoder and power cable

8. **Mount the terminal box lid.** Set the terminal box lid (9) on the motor. Make sure that no wire can be crushed or damaged.
9. Tighten the terminal box lid (9) with the added TFL-coated lid screws (8) with 6.1 Nm.

i If substitute is necessary, please use for lid screws (8) only IS-Screws according to DIN 4762 with a minimum consistency of 8.8!

Note: We recommend at repeated assembling of the terminal box lid, to secure the lid screws (8) with Loctite 243.

Motor connection according to American standard (UL)

MKE037, -047, -098

The connection diagrams by Rexroth are exclusively intended for the preparation of system circuit diagrams!

- Connect the motor as described in the circuit diagram of the machine manufacturer. As additional help, the relevant connecting diagram can be used (see chapter 11.2 "Connecting diagram").

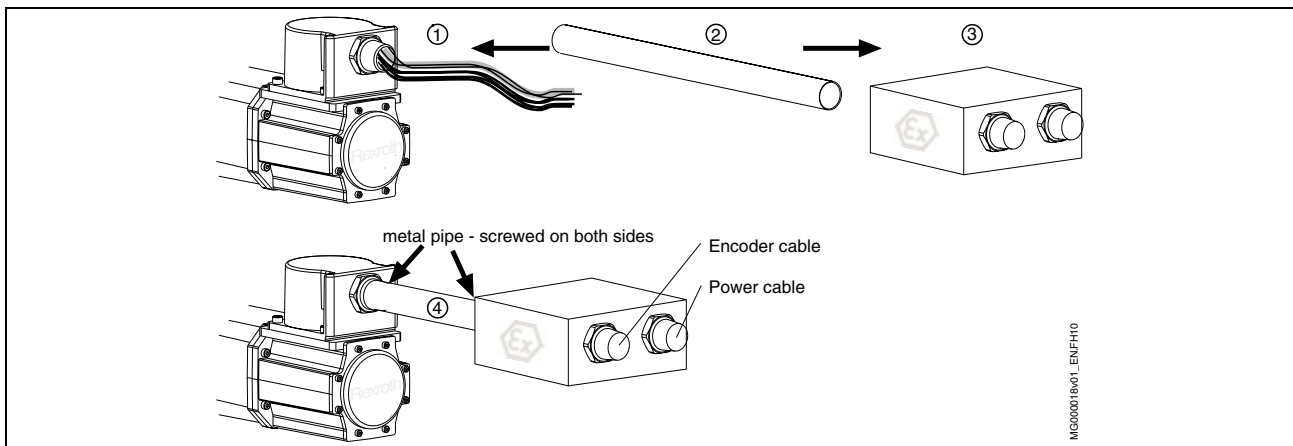

- (1): MKE with connection cable (single conductor)
 (2): steel tube NPT ¼ inch
 (3): Terminal box Ex
 (4): Lead the connection cable into the steel tube

Fig. 11-9 electrical connection

Note: Both the components metal tube (2) and Ex terminal box (3) are not in the scope of delivery.

The machine manufacturer is responsible for observing the respectively guilty standards and instructions.

Apply the shield in the Ex-terminal box as described in the documentation DOK-GENRL*-EMV*****-PRxx-DE-P.

Interconnect the single conductors after the mechanical assembly within the Ex-terminal box according to the connecting diagram (see Fig. 8-5).

MKE118

The connection diagrams by Rexroth are exclusively intended for the preparation of system circuit diagrams!

- Connect the motor as described in the circuit diagram of the machine manufacturer. As additional help, the relevant connecting diagram can be used (see chapter 11.2 “Conneting diagram”).

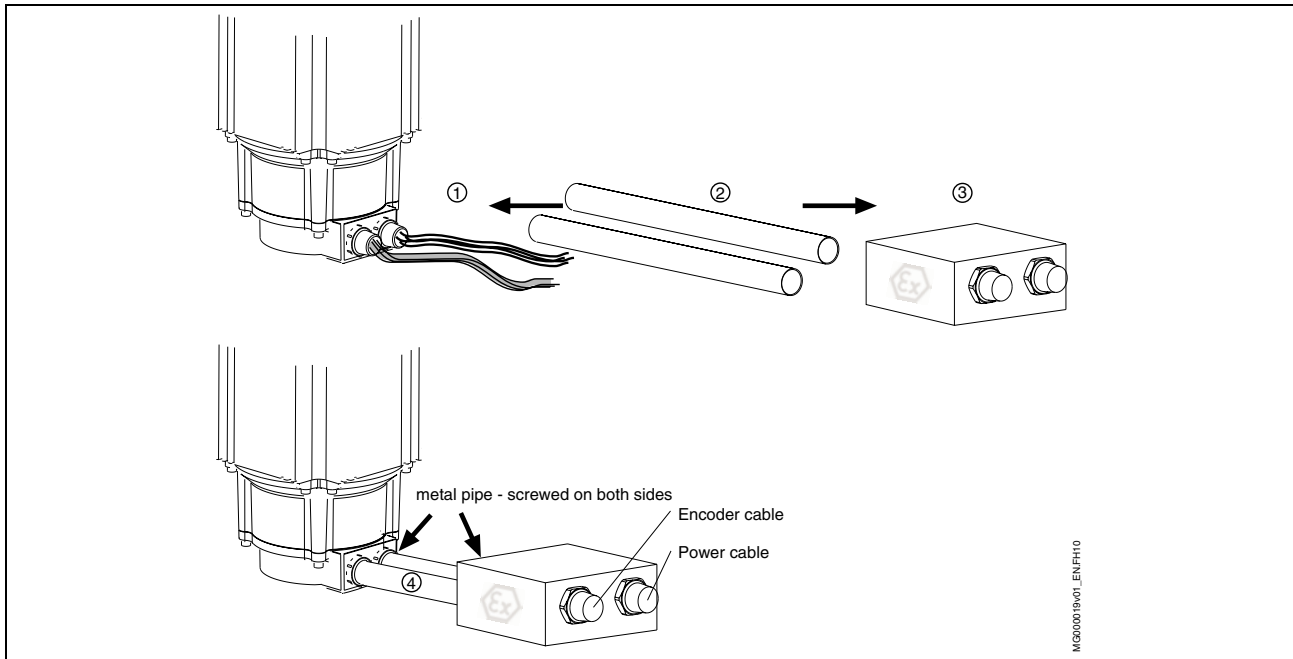

- (1): MKE with connection cable (single conductor)
 (2): steel tube NPT 3/4 inch
 (3): Terminal box Ex
 (4): Lead the connection cable into the steel tube

Fig. 11-10 electrical connection

Note: Both the components metal tube (2) and Ex terminal box (3) are not in the scope of delivery.

The machine manufacturer is responsible for observing the respectively guilty standards and instructions.

Apply the shield in the Ex-terminal box as described in the documentation DOK-GENRL*-EMV*****-PRxx-DE-P.

Interconnect the single conductors after the mechanical assembly within the Ex-terminal box according to the connecting diagram (see Fig. 8-5).

12 Startup, Operation and Maintenance

12.1 Commissioning



CAUTION

Material damage due to errors in activating motors and moving elements! Unclear operating states and product data!

- ⇒ Do not carry out commissioning if connections, operating states or product data are unclear or faulty!
- ⇒ Do not carry out commissioning if the safety and monitoring equipment of the system is damaged or not in operation.
- ⇒ It is not allowed to operate with damaged products!
- ⇒ Contact Rexroth for missing information or support during commissioning!

The following commission notes refer to the MKE motors as part of a drive-system with drive and control devices.

- Preparation**
1. Keep the documentation of all used products ready.
 2. Check the products for damage.
 3. Check all mechanical and electrical connections.
 4. Activate the safety and monitoring equipment of the system.

- Execution** When all prerequisites have been fulfilled, proceed as follows:
1. Activate the optional blower.
 2. Carry out the commission of the drive-system according to the instructions of the respective documentation. You can find the respective information in the functional description of the drive-devices.



Commissioning of drive controllers and the control systems may require additional steps. The inspection of the functioning and performance of the systems is not part of the commissioning of the motor; instead, it is carried out within the framework of the commissioning of the machine as a whole. Observe the information and regulations of the machine manufacturer.

12.2 Operation

Ensure that the ambient conditions described in Chapter 12.4, are kept during operation.

12.3 Deactivation

In the case of malfunctions, maintenance measures or to deactivate the motors, proceed as follows:

1. Observe the instructions of the machine documentation.
2. Use the machine-side control commands to bring the drive to a controlled standstill.
3. Switch off the power and control voltage of the drive controller.
4. Switch off the main switch of the machine.
5. Secure the machine against accidental movements and against unauthorized operation.
6. Wait for the discharge time of the electrical systems to expire and then disconnect all electrical connections.
7. Before dismantling, secure the motor against falling or movements before disconnecting the mechanical connections.

12.4 Maintenance

Synchronous motors of the MKE series operate without wear within the given operating conditions. However, operation under unfavorable conditions can lead to limitations in availability.

⇒ Increase the availability with regular preventive maintenance measures. Notice the information in the maintenance schedule of the machine manufacturer and the described service measures.



Danger of injury due to moving elements! Danger of injury due to hot surfaces!

- ⇒ Do not carry out any maintenance measures when the machine is running.
- ⇒ During maintenance work, secure the system against restarting and unauthorized use.
- ⇒ Do not work on hot surfaces.

Cleaning

Excessive dirt, dust or shavings may affect the function of the motors adversely, may in extreme cases even cause a failure of the motors. For that reason, you should clean

Cooling ribs the cooling ribs of the motors at regular intervals, in order to obtain a sufficiently large heat radiation surface. If the cooling ribs are dirty in part, sufficient heat dissipation via the environmental air is not possible any longer.

An insufficient heat radiation may have undesired consequences. The bearing service life is reduced by operation at impermissibly high temperatures (the bearing grease is decomposing). Switchoff caused by overtemperature despite operation on the basis of selected data, because the appropriate cooling is missing.

Bearing

The nominal service life of the bearings is $L_{10h} = 30.000$ h according to DIN ISO 281, ed. 1990, if the permissible radial and axial forces are not exceeded (see Chapter 16.7). Even if the bearings are loaded with higher forces to a minor degree only, their service life is affected negatively.

The motor bearings should be replaced if

- the nominal bearing service life has been reached,
- running noise can be heard.

Note: We recommend that bearings are replaced by the Bosch Rexroth Service.

Connection Cable

Check connection lines for damage at regular intervals and replace them, if necessary.

Check any optionally present energy management chains (drag chains) for defects.



DANGER

Electrocution by live parts of more than 50 V!

⇒ Do not repair any connection lines provisionally. If the slightest defects are detected in the cable sheath, the system must be put out of operation immediately. Then the cable must be replaced.

Check the protective conductor connection for proper state and tight seat at regular intervals and replace it, if necessary.

Holding brake

In order to ensure proper functioning of the holding brake, it must be checked before the motors are installed.

Before initial startup Measure the holding torque of the brake; grind in the holding brake, if necessary.

Proceed as follows:

1. De-energize the motor and secure it against re-energization.
2. Measure the transmittable holding torque of the holding brake using a torque wrench. The holding torque of the brakes is specified in the data sheets.
3. If the holding torque specified in the data sheets is attained, the holding brake is ready for operation.
If the holding torque specified in the data sheets **is not attained**, the holding brake must be ground in as described in step 4.
4. **Grinding in:** With the holding brake closed, manually turn the output shaft by approx. five revolutions and measure the transmittable holding torque of the brake using a torque spanner.
5. If the holding torque specified in the data sheets is attained, the holding brake is ready for operation.
If the holding torque specified in the data sheets **fails to be reached**, repeat steps 4 and 5 of the grinding-in process.

If the specified holding torque is not attained after the second grinding-in process, the holding brake is not operable. Notify Rexroth Service.

During operation If holding brakes are required only sporadically (braking cycle >48 h) during operation, film rust may develop on the brake friction surface.

To prevent the holding torque from dropping below the specified holding torque, we recommend the grinding procedure described below:

Recommendation for grinding in	
Interval	Once in 48 h
Grinding-in speed	100 rpm
Number of grinding-in revolutions	1
Ambient Temperature	0°C to +40°C

Fig. 12-1: Recommended procedure for grinding in motor holding brakes

Note: The option of automatically implementing the grinding-in routine in the program run is described in the documentation of the particular drive controllers.



During normal operation, it is not necessary to grind in the brake. It is sufficient if the brake is activated twice a day by removing the controller enable signal.

Changing the battery

Drive control systems of Bosch Rexroth observe voltage of battery safely and give just in time a warning "change battery".



DANGER

Danger of Explosion! Death, heavy personal injury and damage by opening the motor housing in hazardous areas!

- ⇒ Do not loosen housing screws when the motor is in hazardous operation.
- ⇒ The MKE motor **must** be brought out of the hazardous area for changing the battery.

Change battery when machine is under load

Changing the battery should be made, when machine is under load. This is necessary to avoid an overrun in the motor encoder (switch off control voltage can cause loss of absolute values).

Change battery

Following tools and spare parts are needed:

Hexagon screw driver for MKE037 Size 2,5
 MKE047 Size 3
 MKE098 Size 4

Needle-nosed pliers

Torque spanner with setting range 1.3-6.8 Nm.

New, ready-made battery for

MKE037 and MKE047	Part No. R911277133
MKE098	Part No. R911281394



DANGER

Danger to life by electric voltage!

To change the battery you must work when machine is under load. Therefore:

Any work required on the electric system may only be carried out by skilled electricians.

Switch off power supply at the drive control systems and save against re-start!



DANGER

Hazardous movements!

Danger to life, mayhem or material damage!

⇒ Switch off power supply at the drive control systems and save against re-start!

⇒ Change battery on drive control systems only when control voltage is inserted. Is the control voltage switched off when the battery is removed, the absolute value is lost and when the machine will be switched on, a failing movement could be possible.

Remove the battery

1. Loosen the internal hexagon screw (1).
2. Take off the encoder lid.
3. Detract the battery connector (2).
4. Loosen screws (3) of the battery's screw terminal and remove the battery.

- Assemble the battery**
1. Connect the ready-made battery according to the motor type and fasten it with the clamping apparatus (4) and the screws (3) (tightening torque maximum 1,0 Nm).

Note: Do not squeeze the battery cable!

2. Attach the battery connector (2).
3. Close the encoder lid.
4. Screw in the hexagon screws (1) and tighten it with a torque spanner. (MKE037 with 3,1 Nm, MKE047 with 1,3 Nm, MKE098 with 6,1 Nm).

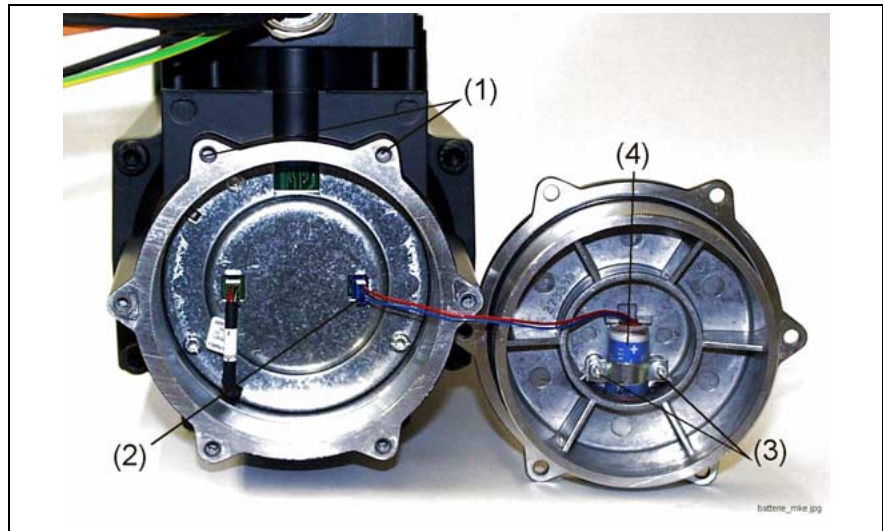

- (1): Use housing screws according to DIN EN ISO 4762 with minimum resistance of 8.8!
- (2): Battery connector
- (3): Screws for mounting the battery.
- (4): Battery

Fig. 12-2: Change battery

- Restart the system**
5. Turn on power supply of drive control system.
 6. Do a testing of the axis.

12.5 Troubleshooting

In
preparation

12.6 Dismantling



DANGER

Fatal injury due to errors in activating motors and moving elements!

- ⇒ Do not work on unsecured and operating machines.
- ⇒ Secure the machine against accidental movements and against unauthorized operation.
- ⇒ Before dismantling, secure the motor and feeder against falling or movements before disconnecting the mechanical connections.

1. Observe the instructions of the machine documentation.
2. Please heed the safety notes and carry out all steps as described in the anterior instructions in the chapter "Deactivation".
3. Before dismantling, secure the motor and feeder against falling or movements before disconnecting the mechanical connections.
4. Dismantle the motor from the machine. Store the motor properly!

12.7 Waste disposal

Manufacturing process The manufacturing process of the products is made in a way that is energy and raw material-optimized and permits a recycling and a utilization of incidental waste.

Bosch Rexroth is trying to replace polluted raw materials and supplies by environmentally alternatives regularly.

Use Bosch Rexroth products do not contain any kind of dangerous substances which could be released at appropriate use. In the normal case it can be reckoned with no negative influences for the environment.

Forbidden substances We guarantee that our products include no substances according to the chemicals-ban-decree. Furthermore, our products are free from quicksilver, asbestos, PCB and chlorinated hydrocarbon.

Substantial composition Basically our motors contain

- steel
- aluminium
- copper
- brass
- magnetic materials
- electronical components

Recycling The products can be predominantly recycled due to the high metal portion. To get an optimum metal recovery, a dismantling of every single component is necessary.

The metals containing electrically and electronically components can be regained by special cutting-off processes, too. The hereby arising plastics could be thermally recycled.

Redemption The products manufactured by us can be returned to our premises for waste disposal at no charge. It is, however supposed, that no disturbing adhesions like oil, grease or other contaminations are contained.

Furthermore it is not allowed that inadequate contaminants or components are contained when the consignment is returned back.

The products have to be delivered "free domicile" to the following address:

Bosch Rexroth AG
Electric Drives and Controls
Bürgermeister-Dr.-Nebel-Strasse 2
97816 Lohr am Main

Packing High-quality products need optimal packaging. The packaging material consists of paper, wood and polystyrene.
They can be recycled everywhere.
In view of ecological reasons, a return transport should not take place.

13 Appendix

13.1 List of standards

Standard	Edition	Title	Concordance
94/9/EG	1994-03-23	Richtlinie 94/9/EG des Europäischen Parlaments und des Rates vom 23. März 1994 zur Angleichung der Rechtsvorschriften der Mitgliedsstaaten für Geräte und Schutzsysteme zur bestimmungsgemäßen Verwendung in explosionsgefährdeten Bereichen	
ATEX-LEITLINIEN	2000-05	ATEX-LEITLINIEN (Erste Ausgabe) Leitlinien zur Anwendung der Richtlinie 94/9/EG des Europäischen Parlaments und des Rates vom 23. März 1994 zur Angleichung der Rechtsvorschriften der Mitgliedsstaaten für Geräte und Schutzsysteme zur bestimmungsgemäßen Verwendung in explosionsgefährdeten Bereichen	
89/336/EWG	1989-05-03	COUNCIL DIRECTIVE of 3 May 1989 on the approximation of the laws of the Member States relating to electromagnetic compatibility (89/336/EEC)	
89/392/EWG ersetzt durch 98/37/EG	1998-06-22	Directive 98/37/EC of the european parliament and of the council of 22 June 1998 on the approximation of the laws of the member states relating to machinery	
DIN 332-2	1983-05	Center holes 60° with thread for shaft ends for rotating electrical machines	
DIN 42948	1965-11	Mounting flanges for rotating electrical machinery	
DIN 42955	1981-12	Tolerances of shaft extension run-out and of mounting flanges for rotating electrical machinery, test	IEC 60072 (1971)
DIN 6885-1	1968-08	Drive Type Fastenings without Taper Action; Parallel Keys, Keyways, Deep Pattern	
DIN 748-3	1975-07	Cylindrical Shaft Ends for Electrical Machines	IEC 60072(1971)
DIN EN 50014, VDE0170/0171 Part 1	2000-02	Electrical apparatus for potentially explosive atmospheres - General requirements; German version EN 50014:1997 + Corrigendum:1998 + A1:1999 + A2:1999	EN 50014(1997-06); EN 50014/A1(1999-02); EN 50014/A2(1999-02)
DIN EN 50014/A3; VDE 0170/0171 Part 1/A3 <i>Entwurf</i>	1998-08	Electrical apparatus for potentially explosive atmospheres - General requirements; Amendment A3; German version EN 50014:1997/prA3:1998	EN 50014/prA3(1998-03)
DIN EN 50014/AA; VDE 0170/0171 Part 1/AA <i>Entwurf</i>	1999-09	Electrical apparatus for potentially explosive atmospheres - General requirements; Amendment AA; German version EN 50014:1997/prAA:1999	EN 50014/prAA(1999-02)
DIN EN 50015; VDE 0170/0171 Part 2	2000-02	Electrical apparatus for potentially explosive atmospheres - Oil-immersion "o"; German version EN 50015:1998	EN 50015(1998-09)
DIN EN 50016/A1; VDE 0170/0171 Part 3/A1 <i>Entwurf</i>	1998-09	Electrical apparatus for potentially explosive atmospheres - Pressurized apparatus "p"; Amendment A1; German version EN 50016:1995/prA1:1998	EN 50016/prA1(1998-03)
DIN EN 50016; VDE 0170/0171 Part 3	1996-05	Electrical apparatus for potentially explosive atmospheres; Pressurized apparatus "p"; German version EN 50016:1995	EN 50016(1995-10)
DIN EN 50017; VDE 0170/0171 Part 4	2000-02	Electrical apparatus for potentially explosive atmospheres - Powder filling "q"; German version EN 50017:1998	EN 50017(1998-09)
DIN EN 50018; VDE 0170/0171 Part 5	1995-03	Electrical apparatus for potentially explosive atmospheres - Flameproof enclosures "d"; German version EN 50018:1994	EN 50018(1994-08)
DIN EN 50019; VDE 0170/0171 Part 6	2001-06	Electrical apparatus for potentially explosive atmospheres - Increased safety "e"; German version EN 50019:2000	EN 50019(2000-07)

DIN EN 50020; VDE 0170/0171 Part 7	1996-04	Electrical apparatus for potentially explosive atmospheres - Intrinsic safety "i"; German version EN 50020:199	EN 50020(1994-08)
DIN EN 50178; VDE 0160	1998-04	Electronic equipment for use in power installations; German version EN 50178:1997	EN 50178(1997-10)
DIN EN 60034-1; VDE 0530 Part 1	2000-09	Rotating electrical machines - Part 1: Rating and performance (IEC 60034-1:1996, modified + A1:1997	EN 60034-1(1998-05); EN 60034-1/A1(1998-05); EN 60034-1/A2(1999-08); IEC 60034-1(1996-11); IEC 60034-1 AMD 1(1997-06); IEC 60034-1 AMD 2(1999-05)
DIN EN 60034-14; VDE 0530 Part 14	1997-09	Rotating electrical machines - Part 14: Mechanical vibration of certain machines with shaft heights 56 mm and higher; measurement, evaluation and limits of vibration (IEC 60034-14:1996); German version EN 60034-14:1996	EN 60034-14(1996-12); IEC 60034-14(1996-11)
DIN EN 60034-7; VDE 0530 Part 7	1996-06	Rotating electrical machines - Part 7: Classification of types of constructions and mounting arrangements (IM code) (IEC 60034-7:1992); German version EN 60034-7:1993	EN 60034-7(1993-01); IEC 60034-7(1992-12)
DIN EN 60079-14; VDE 0165 Part 1	1998-08	Electrical apparatus for explosive gas atmospheres - Part 14: Electrical installations in hazardous areas (other than mines) (IEC 60079-14:1996); German version EN 60079-14:1997	EN 60079-14(1997-08); IEC 60079-14(1996-12)
DIN EN 60529; VDE 0470 Part 1	2000-09	Degrees of protection provided by enclosures (IP code) (IEC 60529:1989 + A1:1999); German version EN 60529:1991+ A1:2000	EN 60529(1991-10); EN 60529/A1(2000-02); IEC 60529(1989-11); IEC 60529 AMD 1 (1999-11)
DIN EN 60721-3-3	1995-09	Classification of environmental conditions - Part 3: Classification of groups of environmental parameters and their severities; section 3: Stationary use at weatherprotected locations (IEC 60721-3-3:1994); German version EN 60721-3-3:1995	EN 60721-3-3(1995-01); IEC 60721-3-3(1994-12)
DIN IEC 60721-1	1997-02	Classification of environmental conditions - Part 1: Environmental parameters and their severities (IEC 60721-1:1990 + A1:1992 + A2:1995); German version EN 60721-1:1995 + A2:1995	EN 60721-1(1995-04); EN 60721-1/A2(1995-07); IEC 60721-1(1990-12); IEC 60721-1 AMD 1(1992-12); IEC 60721-1 AMD 2(1995-04)
DIN VDE 0170/0171-9	1988-07	Electrical apparatus for potentially explosive atmospheres; encapsulation "m"; german version EN 50028:1987	EN 50028(1987-02)
IEC 60072-1	1991-02	Dimensions and output series for rotating electrical machines; part 1: frame numbers 56 to 400 and flange numbers 55 to 1080	
IEC 60072-2	1990-12	Dimensions and output series for rotating electrical machines; part 2: frame numbers 355 to 1000 and flange numbers 1180 to 2360	
IEC 60072-3	1994-03	Dimensions and output series for rotating electrical machines; part 3: small built-in motors; flange numbers BF10 to BF50	
IEC 60364-4-41	1992-10	Electrical installations of buildings; part 4: protection for safety; chapter 41: protection against electric shock	
IEC 60364-4-41 AMD1	1996-02	Electrical installations of buildings; part 4: protection for safety; chapter 41: protection against electric shock; Amendment 1	
IEC 721-1		replaced by DIN IEC 60721-1	
IEC 721-3-3		replaced by DIN IEC 60721-3-3	
UL 1446	1997-05	Systems of insulating materials - General	
UL 508C	1996-11	Power conversion equipment	
UL 674*ANSI 674	1994-04	Electric motors and generators for use in divisions 1 hazardous (classified) locations	

Fig. 13-1: Normenverzeichnis

13.2 Selection of connection cable

In the following see from the documentation "Connection cables, selection data" all selection graphics for all ready-made connection cables for MKE motors of generation 2 (design EN, **type code position 18 = E**).

The wire diameters according to the particular continuous stand-still current for

the power cables can be seen in the following table.

Motor	Cross-section power wire	Fig.
MKE037B-144	1,0	Fig. 13-3
MKE047B-144	1,0	Fig. 13-3
MKE098B-047	1,0	Fig. 13-3
MKE118B-024	2,5	Fig. 13-4
MKE118B-058	6,0	Fig. 13-5
MKE118D-012	2,5	Fig. 13-4
MKE118D-027	2,5	Fig. 13-4
MKE118D-035	6,0	Fig. 13-5

Fig. 13-2: Minimum cross-section power wire

Power cables

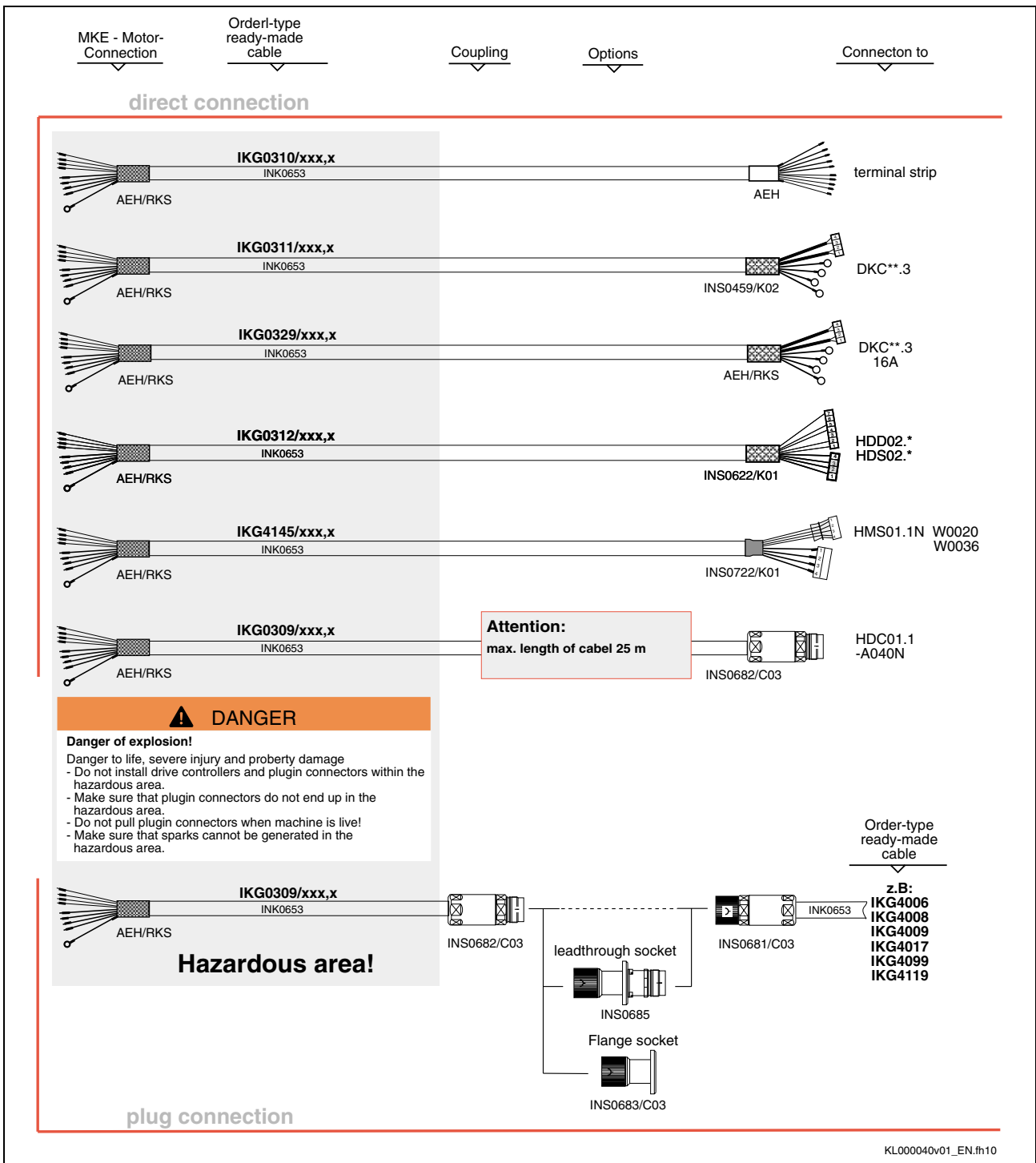

Fig. 13-3: Connection cross-section 1.0 mm² (MKE037, -047, -098)

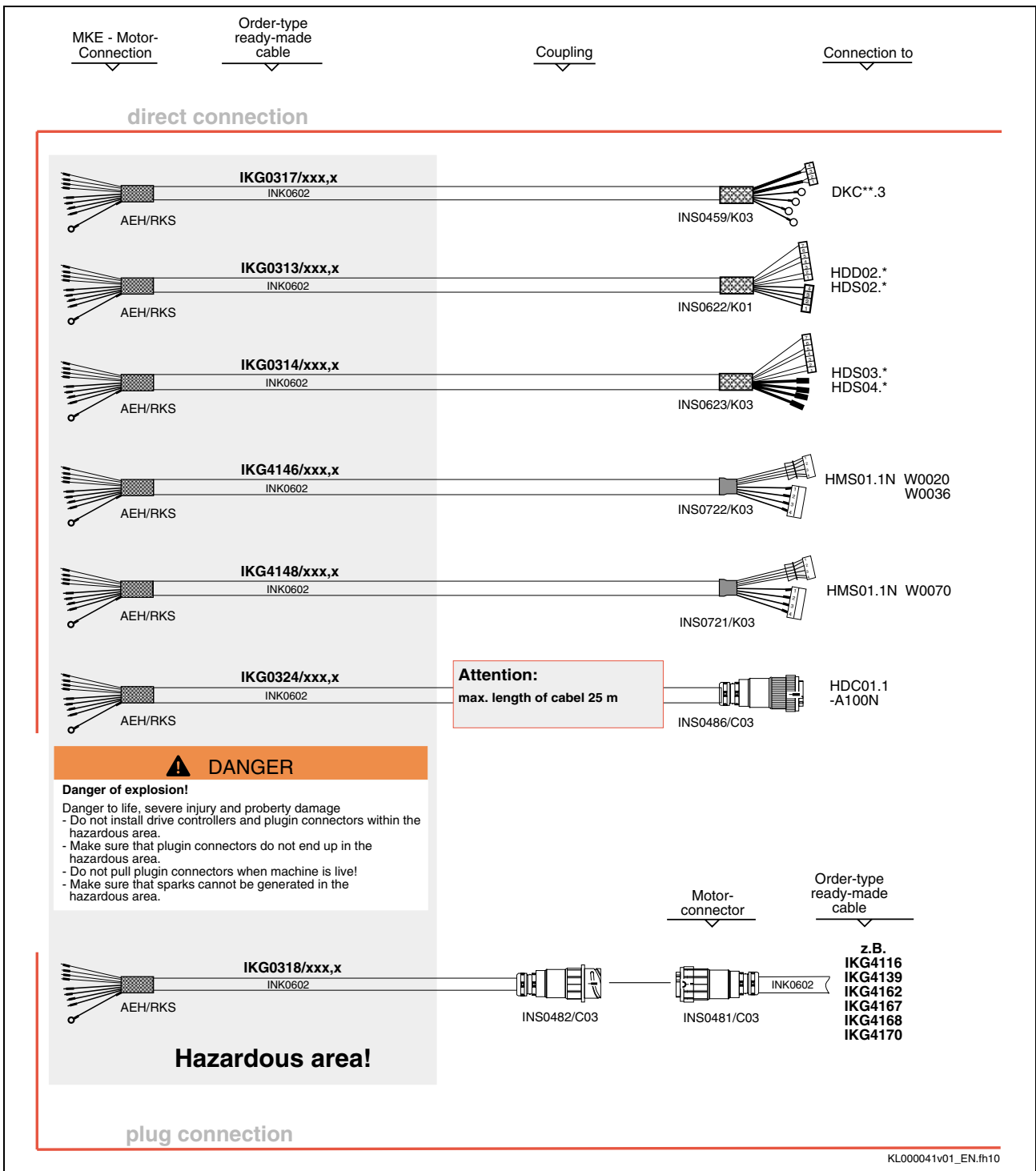

Fig. 13-4: Connection cross-section 2.5 mm² (MKE118)

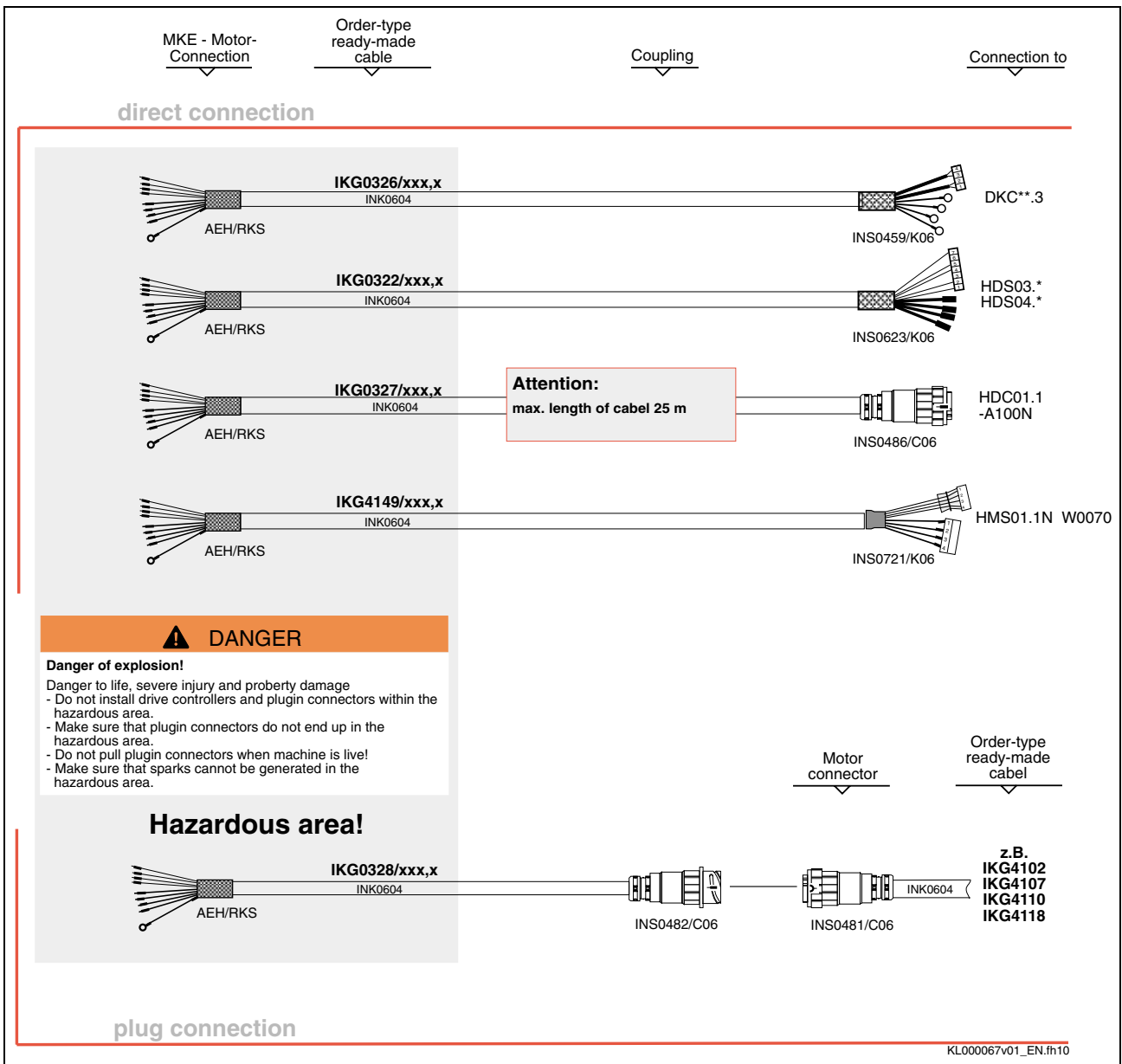

Fig. 13-5: Connection cross-section 6.0 mm² (MKE118)

Encoder cable

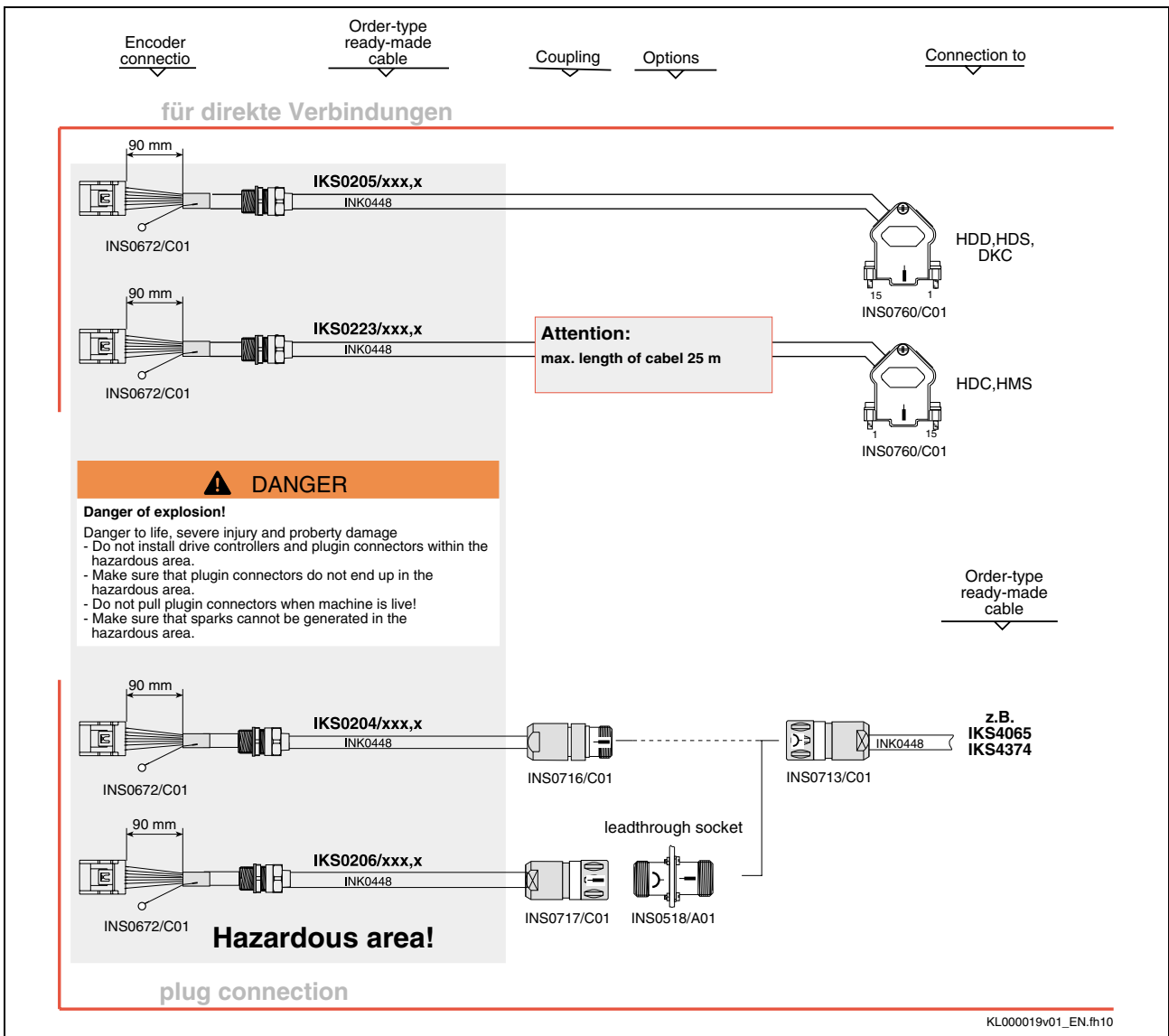

Fig. 13-6: Encoder cable (MKE037, -047, -098)

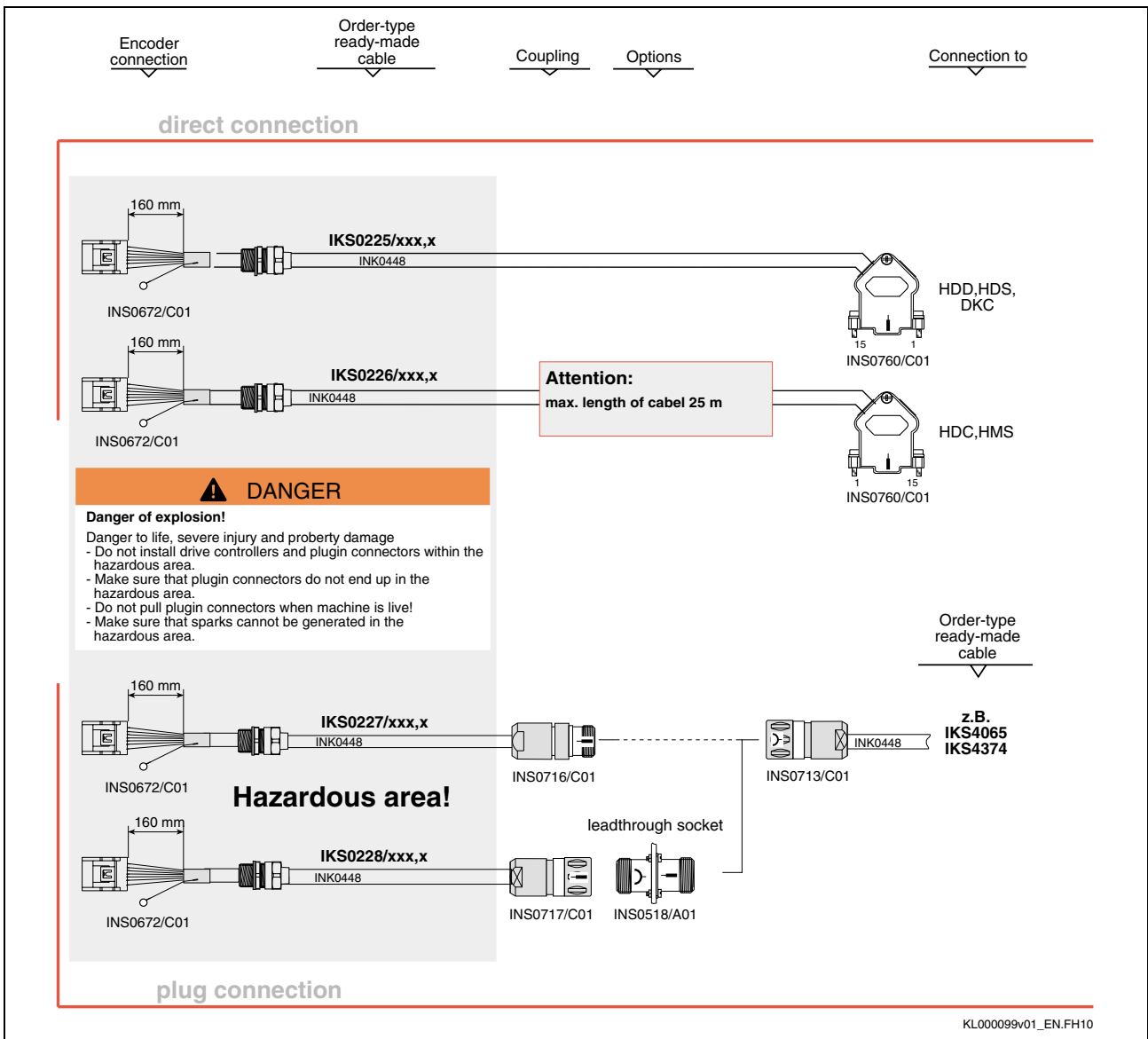

Fig. 13-7 Encoder cable (MKE118)

13.3 Declaration of conformity

A certificate of conformity is attached to every supplied motor. Additional copies can be ordered at your responsible selling agency.

Konformitätserklärung

Im Sinne der EG-Richtlinie 94/9/EG
 Produkt/Product/produit: MKE

RNC 87416-000
 2004-02-09

Declaration of Conformity as per EC directive 94/9/EG
Déclaration du fabricant conformément à la directive "CE" 94/9/EG

Hiermit erklären wir, dass das We herewith declare that the Par la présente nous déclarons que
 Produkt product le produit

1. Produkt:	AC-Motor	
Product:	AC motor	
Produit:	Moteur AC	
2. Hersteller:	Rexroth Indramat GmbH	
Manufacturer:	Bürgermeister-Dr.-Nebel-Straße 2	
Constructeur:	97816 Lohr a. Main / Germany	
3. Typ / Type:	MKE037, MKE047, MKE098, MKE118	
4. ab Herstellungsdatum:	2003-09-15	
from date of manufacture:		
à partir de la date de fabrication:		
5. Angewendete Normen / Applicable standard / Normes utilisées		Ausgabe / Edition
<u>Norm / Standard / Norme</u>	<u>Titel / Title / Titre</u>	
EN 50018	Electrical apparatus for potentially explosive atmospheres - Flameproof enclosure „d“	2001-12
EN 50281-1-1	Electrical apparatus for use in the presence of combustible dust – Part 1-1: Electrical apparatus protected by enclosures; construction and testing	1999-10
EN 50014	Electrical apparatus for potentially explosive atmospheres - General requirements	2000-02
6. Baumusterprüfbescheinigungen		
PTB 03 ATEX 1107 X	Baumusterprüfbescheinigung der PTB, Braunschweig, Germany mit Prüfbericht 03-12133, betreffend MKE037, MKE047, MKE098	
PTB 03 ATEX 1108 X	Baumusterprüfbescheinigung der PTB, Braunschweig, Germany mit Prüfbericht 03-12107, betreffend MKE118	

© Bosch Rexroth AG 2003

einschließlich des erforderlichen including the necessary accessories, satisfait, comme les accessoires
 Zubehörs den Bestimmungen der complies with the provisions of EC nécessaires, aux dispositions de la
 EG-Richtlinie 94/9/EG vom 23. März Directive 94/9/EC dated 23rd March Directive CE 94/9 CE du 23 mars
 1994 entspricht. Die Produkte sind 1994. The product is intended solely 1994. Les produits sont tous, sans
 ausschließlich zum Anbau in eine for installation in a machine. It is exception, destinés être intégrés à
 Maschine bestimmt. Die prohibited to put the product into une machine. La mise en service du
 Inbetriebnahme des Produktes ist operation until it has been produit est proscrite tant qu'il n'a
 solange untersagt, bis festgestellt established that the machine in pas été constaté que la machine
 wurde, dass die Maschine, in die which the product is to be installed dans laquelle ce produit doit être
 das Produkt eingebaut werden soll, complies with the provisions of the monté, répond aux dispositions de la
 den Bestimmungen der EG- EC Directive. directive CE.
 Richtlinie entspricht.

RNC-87416-000_KOE_N_D3_2004-02-09.doc

Rexroth Indramat GmbH
 Bgm.-Dr.-Nebel-Straße 2 • D-97816 Lohr am Main
 Tel. +49 9352 40-0 • Fax +49 9352 40-4885

Page 1 / 2

MX000006v01_D3.tif

Fig. 13-8: Declaration of conformity (page 1)

Erläuterungen:

Der bestimmungsgemäße Gebrauch des Produktes setzt die Einhaltung der Benutzungsbestimmungen und Anwendungsbedingungen, die in der Dokumentation „MKE Synchronmotoren für explosionsgefährdete Bereiche nach ATEX und UL/CSA – Projektierung“ (Dokumentationstyp DOK-MOTOR*-MKE*GEN2***-PRxx-xx-x) angegeben werden, durch den Nutzer voraus.

Der Motor hat die folgende Kennzeichnung:

 II 2 G/D EEx d IIB T4
IP6X T 135°C

Explanations:

For the product to be used as intended the user must comply with the provisions of use and conditions of application laid down in the documentation „MKE synchronous motors for hazardous areas in accordance with ATEX and UL/CSA – Project planning“ (documentation type DOK-MOTOR*-MKE*GEN2***-PRxx-xx-x). The motor has the following markings:

 II 2 G/D EEx d IIB T4
IP6X T 135°C

Explications:

L'utilisation correcte du produit, c'est-à-dire en conformité avec sa destination, présuppose le respect par son utilisateur des prescriptions d'utilisation et conditions d'application stipulées dans la documentation „MKE Moteurs synchrones pour atmosphères explosibles suivant les normes d'études de projet ATEX et UL/CSA“ (Type de documentation DOK-MOTOR*-MKE*GEN2***-PRxx-xx-x). Le moteur a la caractérisation suivante:

 II 2 G/D EEx d IIB T4
IP6X T 135°C

Lohr , den 2004-02-09 i.V.

Ort/location/localité

Datum/date

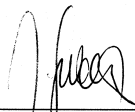
i.V. Jürgen Guldner
Leiter Qualitätsmanagement/
Quality Management/
Responsable Qualité

i.V. Norbert Nellen
Produktsicherheitsbeauftragter/
Product assurance supervisor/
Responsable sécurité de produit

Änderungen im Inhalt der Konformitätserklärung sind vorbehalten. Derzeit gültige Ausgabe auf Anfrage.
We reserve the right to make changes in the conformity declaration. Presently applicable edition can be obtained upon request.
Le fabricant se réserve le droit de modifier le contenu de la déclaration. Edition actuellement en vigueur demande.

Fig. 13-9: Declaration of conformity (page 2)

14 Service & Support

14.1 Helpdesk

Unser Kundendienst-Helpdesk im Hauptwerk Lohr am Main steht Ihnen mit Rat und Tat zur Seite. Sie erreichen uns

Our service helpdesk at our headquarters in Lohr am Main, Germany can assist you in all kinds of inquiries. Contact us

- telefonisch - by phone:
über Service Call Entry Center
- via Service Call Entry Center **49 (0) 9352 40 50 60**
Mo-Fr 07:00-18:00
Mo-Fr 7:00 am - 6:00 pm
- per Fax - by fax: **+49 (0) 9352 40 49 41**
- per e-Mail - by e-mail: service.svc@boschrexroth.de

14.2 Service-Hotline

Außerhalb der Helpdesk-Zeiten ist der Service direkt ansprechbar unter

After helpdesk hours, contact our service department directly at

+49 (0) 171 333 88 26
oder - or **+49 (0) 172 660 04 06**

14.3 Internet

Unter www.boschrexroth.de finden Sie ergänzende Hinweise zu Service, Reparatur und Training sowie die **aktuellen** Adressen *) unserer auf den folgenden Seiten aufgeführten Vertriebs- und Servicebüros.

- Verkaufsniederlassungen
- Niederlassungen mit Kundendienst

Außerhalb Deutschlands nehmen Sie bitte zuerst Kontakt mit unserem für Sie nächstgelegenen Ansprechpartner auf.

*) Die Angaben in der vorliegenden Dokumentation können seit Drucklegung überholt sein.

At www.boschrexroth.de you may find additional notes about service, repairs and training in the Internet, as well as the **actual** addresses *) of our sales- and service facilities figuring on the following pages.

- sales agencies
- offices providing service

Please contact our sales / service office in your area first.

*) Data in the present documentation may have become obsolete since printing.

14.4 Vor der Kontaktaufnahme... - Before contacting us...

Wir können Ihnen schnell und effizient helfen wenn Sie folgende Informationen bereithalten:

1. detaillierte Beschreibung der Störung und der Umstände.
2. Angaben auf dem Typenschild der betreffenden Produkte, insbesondere Typenschlüssel und Seriennummern.
3. Tel./Faxnummern und e-Mail-Adresse, unter denen Sie für Rückfragen zu erreichen sind.

For quick and efficient help, please have the following information ready:

1. Detailed description of the failure and circumstances.
2. Information on the type plate of the affected products, especially type codes and serial numbers.
3. Your phone/fax numbers and e-mail address, so we can contact you in case of questions.

14.5 Kundenbetreuungsstellen - Sales & Service Facilities

Deutschland – Germany

vom Ausland: (0) nach Landeskennziffer weglassen!
from abroad: don't dial (0) after country code!

Vertriebsgebiet Mitte Germany Centre Rexroth Indramat GmbH Bgm.-Dr.-Nebel-Str. 2 / Postf. 1357 97816 Lohr am Main / 97803 Lohr Kompetenz-Zentrum Europa Tel.: +49 (0)9352 40-0 Fax: +49 (0)9352 40-4885	SERVICE CALL ENTRY CENTER MO – FR von 07:00 - 18:00 Uhr from 7 am – 6 pm Tel. +49 (0) 9352 40 50 60 Service.brc@boschrexroth.de	SERVICE HOTLINE MO – FR von 17:00 - 07:00 Uhr from 5 pm - 7 am + SA / SO Tel.: +49 (0)172 660 04 06 oder / or Tel.: +49 (0)171 333 88 26	SERVICE ERSATZTEILE / SPARES verlängerte Ansprechzeit - extended office time - ♦ nur an Werktagen - only on working days - ♦ von 07:00 - 18:00 Uhr - from 7 am - 6 pm - Tel. +49 (0) 9352 40 42 22
Vertriebsgebiet Süd Germany South Rexroth Indramat GmbH Landshuter Allee 8-10 80637 München Tel.: +49 (0)89 127 14-0 Fax: +49 (0)89 127 14-490	Vertriebsgebiet West Germany West Bosch Rexroth AG Regionalzentrum West Borsigstrasse 15 40880 Ratingen Tel.: +49 (0)2102 409-0 Fax: +49 (0)2102 409-406	Gebiet Südwest Germany South-West Bosch Rexroth AG Service-Regionalzentrum Süd-West Siemensstr.1 70736 Fellbach Tel.: +49 (0)711 51046-0 Fax: +49 (0)711 51046-248	Gebiet Südwest Germany South-West Bosch Rexroth AG Regionalzentrum Südwest Ringstrasse 70 / Postfach 1144 70736 Fellbach / 70701 Fellbach Tel.: +49 (0)711 57 61-100 Fax: +49 (0)711 57 61-125
Vertriebsgebiet Nord Germany North Bosch Rexroth AG Walsroder Str. 93 30853 Langenhagen Tel.: +49 (0) 511 72 66 57-0 Service: +49 (0) 511 72 66 57-256 Fax: +49 (0) 511 72 66 57-93 Service: +49 (0) 511 72 66 57-95	Vertriebsgebiet Mitte Germany Centre Bosch Rexroth AG Regionalzentrum Mitte Waldecker Straße 13 64546 Mörfelden-Walldorf Tel.: +49 (0) 61 05 702-3 Fax: +49 (0) 61 05 702-444	Vertriebsgebiet Ost Germany East Bosch Rexroth AG Beckerstraße 31 09120 Chemnitz Tel.: +49 (0)371 35 55-0 Fax: +49 (0)371 35 55-333	Vertriebsgebiet Ost Germany East Bosch Rexroth AG Regionalzentrum Ost Walter-Köhn-Str. 4d 04356 Leipzig Tel.: +49 (0)341 25 61-0 Fax: +49 (0)341 25 61-111

Europa (West) - Europe (West)

vom Ausland: (0) nach Landeskennziffer weglassen, **Italien:** 0 nach Landeskennziffer mitwählen
from abroad: don't dial (0) after country code, **Italy:** dial 0 after country code

Austria - Österreich Bosch Rexroth GmbH Bereich Indramat Stachegasse 13 1120 Wien Tel.: +43 (0)1 985 25 40 Fax: +43 (0)1 985 25 40-93	Austria – Österreich Bosch Rexroth GmbH Gesch.ber. Rexroth Indramat Industriepark 18 4061 Pasching Tel.: +43 (0)7221 605-0 Fax: +43 (0)7221 605-21	Belgium - Belgien Bosch Rexroth AG Electric Drives & Controls Industrielaan 8 1740 Ternat Tel.: +32 (0)2 5830719 - service: +32 (0)2 5830717 Fax: +32 (0)2 5830731 indramat@boschrexroth.be	Denmark - Dänemark BEC A/S Zinkvej 6 8900 Randers Tel.: +45 (0)87 11 90 60 Fax: +45 (0)87 11 90 61
Great Britain – Großbritannien Bosch Rexroth Ltd. Rexroth Indramat Division Broadway Lane, South Cerney Cirencester, Glos GL7 5UH Tel.: +44 (0)1285 863000 Fax: +44 (0)1285 863030 sales@boschrexroth.co.uk service@boschrexroth.co.uk	Finland - Finnland Bosch Rexroth Oy Rexroth Indramat division Ansatie 6 017 40 Vantaa Tel.: +358 (0)9 84 91-11 Fax: +358 (0)9 84 91-13 60	France - Frankreich Bosch Rexroth SAS Division Rexroth Indramat Avenue de la Trentaine (BP. 74) 77503 Chelles Cedex Tel.: +33 (0)164 72-70 00 Fax: +33 (0)164 72-63 00 Hotline: +33 (0)608 33 43 28	France - Frankreich Bosch Rexroth SAS Division Rexroth Indramat ZI de Thibaud, 20 bd. Thibaud (BP. 1751) 31084 Toulouse Tel.: +33 (0)5 61 43 61 87 Fax: +33 (0)5 61 43 94 12
France - Frankreich Bosch Rexroth SAS Division Rexroth Indramat 91, Bd. Irène Joliot-Curie 69634 Vénissieux – Cedex Tel.: +33 (0)4 78 78 53 65 Fax: +33 (0)4 78 78 53 62	Italy - Italien Bosch Rexroth S.p.A. Via G. Di Vittoria, 1 20063 Cernusco S/N.MI Tel.: +39 02 92 365 1 +39 02 92 365 326 Fax: +39 02 92 365 500 +39 02 92 365 516378	Italy - Italien Bosch Rexroth S.p.A. Via Paolo Veronesi, 250 10148 Torino Tel.: +39 011 224 88 11 Fax: +39 011 224 88 30	Italy - Italien Bosch Rexroth S.p.A. Via del Progresso, 16 (Zona Ind.) 35020 Padova Tel.: +39 049 8 70 13 70 Fax: +39 049 8 70 13 77
Italy - Italien Bosch Rexroth S.p.A. Via Mascia, 1 80053 Castellammare di Stabia NA Tel.: +39 081 8 71 57 00 Fax: +39 081 8 71 68 85	Italy - Italien Bosch Rexroth S.p.A. Viale Oriani, 38/A 40137 Bologna Tel.: +39 051 34 14 14 Fax: +39 051 34 14 22	Netherlands – Niederlande/Holland Bosch Rexroth B.V. Kruisbroeksestraat 1 (P.O. Box 32) 5281 RV Boxtel Tel.: +31 (0)411 65 19 51 Fax: +31 (0)411 65 14 83 www.boschrexroth.nl	Netherlands - Niederlande/Holland Bosch Rexroth Services B.V. Technical Services Kruisbroeksestraat 1 (P.O. Box 32) 5281 RV Boxtel Tel.: +31 (0)411 65 19 51 Fax: +31 (0)411 67 78 14 services@boschrexroth.nl
Norway - Norwegen Bosch Rexroth AS Rexroth Indramat Division Berghagan 1 or: Box 3007 1405 Ski-Langhus 1402 Ski Tel.: +47 (0)64 86 41 00 Fax: +47 (0)64 86 90 62 jul.ruud@rexroth.no	Spain - Spanien Bosch Rexroth S.A. División Rexroth Indramat Centro Industrial Santiga Obradors s/n 08130 Santa Perpetua de Mogoda Barcelona Tel.: +34 9 37 47 94 00 Fax: +34 9 37 47 94 01	Spain – Spanien Goimendi S.A. División Rexroth Indramat Parque Empresarial Zuatzu C/ Francisco Grandmontagne no.2 20018 San Sebastian Tel.: +34 9 43 31 84 21 - service: +34 9 43 31 84 56 Fax: +34 9 43 31 84 27 - service: +34 9 43 31 84 60 sat.indramat@goimendi.es	Sweden - Schweden Rexroth Mecman Svenska AB Rexroth Indramat Division - Varuvägen 7 (Service: Konsumentvägen 4, Älfsjö) 125 81 Stockholm Tel.: +46 (0)8 727 92 00 Fax: +46 (0)8 647 32 77
Sweden - Schweden Rexroth Mecman Svenska AB Indramat Support Ekvändan 7 254 67 Helsingborg Tel.: +46 (0) 42 38 88 -50 Fax: +46 (0) 42 38 88 -74	Switzerland West - Schweiz West Bosch Rexroth Suisse SA Département Rexroth Indramat Rue du village 1 1020 Renens Tel.: +41 (0)21 632 84 20 Fax: +41 (0)21 632 84 21	Switzerland East - Schweiz Ost Bosch Rexroth Schweiz AG Geschäftsbereich Indramat Hemrietstrasse 2 8863 Buttikon Tel. +41 (0) 55 46 46 111 Fax +41 (0) 55 46 46 222	

Europa (Ost) - Europe (East)

vom Ausland: (0) nach Landeskenziffer weglassen
from abroad: don't dial (0) after country code

<p>Czech Republic - Tschechien</p> <p>Bosch -Rexroth, spol.s.r.o. Hviezdoslavova 5 627 00 Brno Tel.: +420 (0)5 48 126 358 Fax: +420 (0)5 48 126 112</p>	<p>Czech Republic - Tschechien</p> <p>DEL a.s. Strojirenská 38 591 01 Zdar nad Sázavou Tel.: +420 566 64 3144 Fax: +420 566 62 1657</p>	<p>Hungary - Ungarn</p> <p>Bosch Rexroth Kft. Angol utca 34 1149 Budapest Tel.: +36 (1) 422 3200 Fax: +36 (1) 422 3201</p>	<p>Poland – Polen</p> <p>Bosch Rexroth Sp.zo.o. ul. Staszica 1 05-800 Pruszków Tel.: +48 22 738 18 00 – service: +48 22 738 18 46 Fax: +48 22 758 87 35 – service: +48 22 738 18 42</p>
<p>Poland – Polen</p> <p>Bosch Rexroth Sp.zo.o. Biuro Poznan ul. Dabrowskiego 81/85 60-529 Poznan Tel.: +48 061 847 64 62 /-63 Fax: +48 061 847 64 02</p>	<p>Romania - Rumänien</p> <p>East Electric S.R.L. B-dul Basarabie, nr.250, sector 3 73429 Bucuresti Tel./Fax: +40 (0)21 255 35 07 +40 (0)21 255 77 13 Fax: +40 (0)21 725 61 21 est@mb.roknet.ro</p>	<p>Romania - Rumänien</p> <p>Bosch Rexroth Sp.zo.o. Str. Drobety nr. 4-10, app. 14 70258 Bucuresti, Sector 2 Tel.: +40 (0)1 210 48 25 +40 (0)1 210 29 50 Fax: +40 (0)1 210 29 52</p>	<p>Russia - Russland</p> <p>Bosch Rexroth OOO Wjatskaja ul. 27/15 127015 Moskau Tel.: +7-095-785 74 78 +7-095 785 74 79 Fax: +7 095 785 74 77 laura.kanina@boschrexroth.ru</p>
<p>Russia - Russland</p> <p>ELMIS 10, Internationalnaya 246640 Gomel, Belarus Tel.: +375/ 232 53 42 70 +375/ 232 53 21 69 Fax: +375/ 232 53 37 69 elmis_ltd@yahoo.com</p>	<p>Turkey - Türkei</p> <p>Bosch Rexroth Otomasyon San & Tic. A..S. Fevzi Cakmak Cad No. 3 34630 Sefaköy Istanbul Tel.: +90 212 541 60 70 Fax: +90 212 599 34 07</p>	<p>Slowenia - Slowenien</p> <p>DOMEL Otoki 21 64 228 Zelezniki Tel.: +386 5 5117 152 Fax: +386 5 5117 225 brane.ozebek@domel.si</p>	

Africa, Asia, Australia – incl. Pacific Rim

<p>Australia - Australien</p> <p>AIMS - Australian Industrial Machinery Services Pty. Ltd. 28 Westside Drive Laverton North Vic 3026 Melbourne</p> <p>Tel.: +61 3 93 243 321 Fax: +61 3 93 243 329 Hotline: +61 4 19 369 195 terryobrien@aimservices.com.au</p>	<p>Australia - Australien</p> <p>Bosch Rexroth Pty. Ltd. No. 7, Endeavour Way Braeside Victoria, 31 95 Melbourne</p> <p>Tel.: +61 3 95 80 39 33 Fax: +61 3 95 80 17 33 mel@rexroth.com.au</p>	<p>China</p> <p>Shanghai Bosch Rexroth Hydraulics & Automation Ltd. Waigaoqiao, Free Trade Zone No.122, Fu Te Dong Yi Road Shanghai 200131 - P.R.China</p> <p>Tel.: +86 21 58 66 30 30 Fax: +86 21 58 66 55 23 richard.yang_sh@boschrexroth.com.cn qf.zhu_sh@boschrexroth.com.cn</p>	<p>China</p> <p>Shanghai Bosch Rexroth Hydraulics & Automation Ltd. 4/f, Marine Tower No.1, Pudong Avenue Shanghai 200120 - P.R.China</p> <p>Tel.: +86 21 68 86 15 88 Fax: +86 21 58 40 65 77</p>
<p>China</p> <p>Bosch Rexroth China Ltd. 15/F China World Trade Center 1, Jianguomenwai Avenue Beijing 100004, P.R.China</p> <p>Tel.: +86 10 65 05 03 80 Fax: +86 10 65 05 03 79</p>	<p>China</p> <p>Bosch Rexroth China Ltd. Guangzhou Repres. Office Room 1014-1016, Metro Plaza, Tian He District, 183 Tian He Bei Rd Guangzhou 510075, P.R.China</p> <p>Tel.: +86 20 8755-0030 +86 20 8755-0011 Fax: +86 20 8755-2387</p>	<p>China</p> <p>Bosch Rexroth (China) Ltd. A-5F., 123 Lian Shan Street Sha He Kou District Dalian 116 023, P.R.China</p> <p>Tel.: +86 411 46 78 930 Fax: +86 411 46 78 932</p>	<p>China</p> <p>Melchers GmbH BRC-SE, Tightening & Press-fit 13 Floor Est Ocean Centre No.588 Yanan Rd. East 65 Yanan Rd. West Shanghai 200001</p> <p>Tel.: +86 21 6352 8848 Fax: +86 21 6351 3138</p>
<p>Hongkong</p> <p>Bosch Rexroth (China) Ltd. 6th Floor, Yeung Yiu Chung No.6 Ind Bldg. 19 Cheung Shun Street Cheung Sha Wan, Kowloon, Hongkong</p> <p>Tel.: +852 22 62 51 00 Fax: +852 27 41 33 44 alexis.siu@boschrexroth.com.hk</p>	<p>India - Indien</p> <p>Bosch Rexroth (India) Ltd. Rexroth Indramat Division Plot. A-58, TTC Industrial Area Thane Turbhe Midc Road Mahape Village Navi Mumbai - 400 701</p> <p>Tel.: +91 22 7 61 46 22 Fax: +91 22 7 68 15 31</p>	<p>India - Indien</p> <p>Bosch Rexroth (India) Ltd. Rexroth Indramat Division Plot. 96, Phase III Peenya Industrial Area Bangalore - 560058</p> <p>Tel.: +91 80 41 17 02 -11...-18 Fax: +91 80 83 94 345 +91 80 83 97 374 mohanvelu.t@boschrexroth.co.in</p>	<p>India - Indien</p> <p>Bosch Rexroth (India) Ltd. 1st Floor, S-10 Green Park ext. Market New Delhi – 110016</p> <p>Tel.: +91 1 16 56 68 88 Fax: +91 1 16 56 68 87</p>
<p>Indonesia - Indonesien</p> <p>PT. Bosch Rexroth Building # 202, Cilandak Commercial Estate Jl. Cilandak KKO, Jakarta 12560</p> <p>Tel.: +62 21 7891169 (5 lines) Fax: +62 21 7891170 - 71</p>	<p>Japan</p> <p>Bosch Rexroth Automation Corp. Service Center Japan Yutakagaoka 1810, Meito-ku, NAGOYA 465-0035, Japan</p> <p>Tel.: +81 52 777 88 41 +81 52 777 88 53 +81 52 777 88 79 Fax: +81 52 777 89 01</p>	<p>Japan</p> <p>Bosch Rexroth Automation Corp. Rexroth Indramat Division 1F, I.R. Building Nakamachidai 4-26-44, Tsuzuki-ku YOKOHAMA 224-0041, Japan</p> <p>Tel.: +81 45 942 72 10 Fax: +81 45 942 03 41</p>	<p>Korea</p> <p>Bosch Rexroth-Korea Ltd. Electric Drives and Controls Bongwoo Bldg. 7FL, 31-7, 1Ga Jangchoong-dong, Jung-gu Seoul, 100-391</p> <p>Tel.: +82 234 061 813 Fax: +82 222 641 295</p>
<p>Korea</p> <p>Bosch Rexroth-Korea Ltd. 1515-14 Dadae-Dong, Saha-Ku Rexroth Indramat Division Pusan Metropolitan City, 604-050</p> <p>Tel.: +82 51 26 00 741 Fax: +82 51 26 00 747 gyhan@rexrothkorea.co.kr</p>	<p>Malaysia</p> <p>Bosch Rexroth Sdn.Bhd. 11, Jalan U8/82, Seksyen U8 40150 Shah Alam Selangor, Malaysia</p> <p>Tel.: +60 3 78 44 80 00 Fax: +60 3 78 45 48 00 hockhwa@hotmail.com rexroth1@tm.net.my</p>	<p>Singapore - Singapur</p> <p>Bosch Rexroth Pte Ltd 15D Tuas Road Singapore 638520</p> <p>Tel.: +65 68 61 87 33 Fax: +65 68 61 18 25 sanjay.nemade@boschrexroth.com.sg</p>	<p>South Africa - Südafrika</p> <p>TECTRA Automation (Pty) Ltd. 71 Watt Street, Meadowdale Edenvale 1609</p> <p>Tel.: +27 11 971 94 00 Fax: +27 11 971 94 40 Hotline: +27 82 903 29 23 georgv@tectra.co.za</p>
<p>Taiwan</p> <p>Rexroth Uchida Co., Ltd. No.17, Alley 24, Lane 737 Cheng Bei 1 Rd., Yungkang Tainan Hsien</p> <p>Tel.: +886 6 25 36 565 Fax: +886 6 25 34 754 indra.charlie@msa.hinet.net</p>	<p>Thailand</p> <p>NC Advance Technology Co. Ltd. 59/76 Moo 9 Ramindra road 34 Tharang, Bangkhen, Bangkok 10230</p> <p>Tel.: +66 2 943 70 62 +66 2 943 71 21 Fax: +66 2 509 23 62 sonkawin@hotmail.com</p>		

Nordamerika – North America

USA Headquarters - Hauptniederlassung Bosch Rexroth Corporation Rexroth Indramat Division 5150 Prairie Stone Parkway Hoffman Estates, IL 60192-3707 Tel.: +1 847 6 45 36 00 Fax: +1 847 6 45 62 01 servicebrc@boschrexroth-us.com repairbrc@boschrexroth-us.com	USA Central Region - Mitte Bosch Rexroth Corporation Rexroth Indramat Division Central Region Technical Center 1701 Harmon Road Auburn Hills, MI 48326 Tel.: +1 248 3 93 33 30 Fax: +1 248 3 93 29 06	USA Southeast Region - Südwest Bosch Rexroth Corporation Rexroth Indramat Division Southeastern Technical Center 3625 Swiftwater Park Drive Suwanee, Georgia 30124 Tel.: +1 770 9 32 32 00 Fax: +1 770 9 32 19 03	USA SERVICE-HOTLINE - 7 days x 24hrs - +1-800-860-1055
USA East Region – Ost Bosch Rexroth Corporation Rexroth Indramat Division Charlotte Regional Sales Office 14001 South Lakes Drive Charlotte, North Carolina 28273 Tel.: +1 704 5 83 97 62 +1 704 5 83 14 86	USA Northeast Region – Nordost Bosch Rexroth Corporation Rexroth Indramat Division Northeastern Technical Center 99 Rainbow Road East Granby, Connecticut 06026 Tel.: +1 860 8 44 83 77 Fax: +1 860 8 44 85 95	USA West Region – West Bosch Rexroth Corporation 7901 Stoneridge Drive, Suite 220 Pleasant Hill, California 94588 Tel.: +1 925 227 10 84 Fax: +1 925 227 10 81	
Canada East - Kanada Ost Bosch Rexroth Canada Corporation Burlington Division 3426 Mainway Drive Burlington, Ontario Canada L7M 1A8 Tel.: +1 905 335 55 11 +1 905 335-41 84 michael.moro@boschrexroth.ca	Canada West - Kanada West Bosch Rexroth Canada Corporation 5345 Goring St. Burnaby, British Columbia Canada V7J 1R1 Tel.: +1 604 205-5777 Fax: +1 604 205-6944 david.gunby@boschrexroth.ca	Mexico Bosch Rexroth Mexico S.A. de C.V. Calle Neptuno 72 Unidad Ind. Vallejo 07700 Mexico, D.F. Tel.: +52 5 754 17 11 +52 5 754 36 84 +52 5 754 12 60 Fax: +52 5 754 50 73 +52 5 752 59 43 mariofelipe.hernandez@boschrexroth.com.mx	Mexico Bosch Rexroth S.A. de C.V. Calle Argentina No 3913 Fracc. las Torres 64930 Monterrey, N.L. Tel.: +52 8 333 88 34...36 +52 8 349 80 91...93 Fax: +52 8 346 78 71 mario.quiroga@boschrexroth.com.mx

Südamerika – South America

Argentina - Argentinien Bosch Rexroth S.A.I.C. "The Drive & Control Company" Acassuso 48 41/47 1605 Munro Provincia de Buenos Aires Tel.: +54 11 4756 01 40 Fax: +54 11 4756 01 36 victor.jabif@boschrexroth.com.ar	Argentina - Argentinien NAKASE Servicio Tecnico CNC Calle 49, No. 5764/66 B1653AOX Villa Balester Provincia de Buenos Aires Tel.: +54 11 4768 36 43 Fax: +54 11 4768 24 13 nakase@usa.net nakase@nakase.com gerencia@nakase.com (Service)	Brazil - Brasilien Bosch Rexroth Ltda. Av. Tégula, 888 Ponte Alta, Atibaia SP CEP 12942-440 Tel.: +55 11 4414 56 92 +55 11 4414 56 84 Fax sales: +55 11 4414 57 07 Fax serv.: +55 11 4414 56 86 alexandre.wittwer@rexroth.com.br	Brazil - Brasilien Bosch Rexroth Ltda. R. Dr.Humberto Pinheiro Vieira, 100 Distrito Industrial [Caixa Postal 1273] 89220-390 Joinville - SC Tel./Fax: +55 47 473 58 33 Mobil: +55 47 9974 6645 prochnow@zaz.com.br
Columbia - Kolumbien Reflutec de Colombia Ltda. Calle 37 No. 22-31 Santafé de Bogotá, D.C. Colombia Tel.: +57 1 368 82 67 +57 1 368 02 59 Fax: +57 1 268 97 37 reflutec@neutel.com.co reflutec@007mundo.com			

15 Index

B

Bearing
Wear 9-23
Bearing failure 9-23
Brake torque 9-25

C

Characteristic continuous operation curve 4-4
Characteristic motor speed 4-3
Characteristic voltage limit curves 4-4
Connection Cable 12-3
Continuous current at standstill 4-3
Continuous torque at standstill 4-3
Cooling ribs 12-2
Cycle duration 4-2
Cyclic duration factor 4-2

D

Degree of protection 9-14
Drag chains 12-3

E

Encoder system 6-2
Energy management chains 12-3

G

Grease consumption duration 9-23

H

Heat dissipation 12-2
Holding brake
electrically clamping 9-25
electrically releasing 9-25
Grinding in 12-4
Note regarding danger 9-24
Release delay 9-25

I

Identification 10-2
Idle time 4-2
Intended use
Introduction 2-1
Requirements 2-1

K

Keyway 6-3

L

Lifting sling belts 10-3
Locking screws 11-2

M

Mass 4-3
Maximum speed 4-3
Mean speed 9-21, 9-23
Moment of inertia of the rotor 4-3

N

Non-intended use 2-2
 Consequences, disclaimer of liability 2-1
Number of pole pairs 4-3

O

ON time 4-2
Operating modes 4-2
Output shaft
 Plain shaft 6-3
Outside systems 1-5

P

Peak current 4-3
Processing cycle 9-21

R

Radial shaft sealing ring 4-1, 9-18
Redundant bearing 9-22
Running noise 12-3

S

Safety Instructions for Electric Drives and Controls 3-1
Shaft sealing ring 9-18
Standards 1-5

T

Theoretical maximum torque 4-3
Thermal limit curves 4-4
Thermal time constant 4-3
Tightness 9-19
Torque constant 4-3

V

Vibrations, sinusoidal 9-16
Voltage constant 4-3

W

Winding inductivity 4-3
Winding resistance 4-3

Bosch Rexroth AG
Electric Drives and Controls
P.O. Box 13 57
97803 Lohr, Germany
Bgm.-Dr.-Nebel-Str. 2
97816 Lohr, Germany
Phone +49 93 52-40-50 60
Fax +49 93 52-40-49 41
service.svc@boschrexroth.de
www.boschrexroth.com

